

viscount

Prestige Organs



Manuale Avanzato - IT
Advanced Manual - EN
Komplettes Handbuch - DE

IMPORTANT SAFETY INSTRUCTIONS

WARNING: READ THIS FIRST!

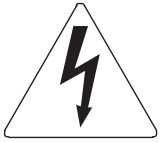

This symbol is intended to alert the user to the presence of uninsulated "dangerous voltage" within the product's enclosure that may be of sufficient magnitude to constitute a risk of electric shock to persons.



This symbol is intended to alert the user to the presence of important operating and maintenance (servicing) instructions in the literature accompanying the appliance.

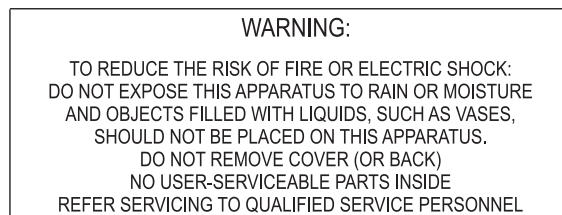

"INSTRUCTIONS PERTAINING TO A RISK OF FIRE, ELECTRIC SHOCK, OR INJURY TO PERSONS"

WARNING:

- 1) Read these instructions.
- 2) Keep these instructions.
- 3) Heed all warnings.
- 4) Follow all instructions.
- 5) Do not use this apparatus near water.
- 6) Clean only with dry cloth.
- 7) Do not block any ventilation openings. Install in accordance with the manufacturer's instructions.
- 8) Do not install near any heat sources such as radiators, heat registers, stoves, or other apparatus (including amplifiers) that produces heat.
- 9) Do not defeat the safety purpose of the polarized or grounding-type plug. A polarized plug has two blades with one wider than the other. A grounding type plug has two blades and a third grounding prong. The wider blade or the third prong are provided for your safety. If the provided plug does not fit in to your outlet, consult an electrician for replacement of the obsolete outlet.
- 10) Protect the power cord from being walked on or pinched, particularly at plugs, convenience receptacles, and the point where they exit from the apparatus.
- 11) Only use attachments/accessories specified by the manufacturer.
- 12) Use only with the cart, stand, tripod, bracket, or table specified by the manufacturer, or sold, with the apparatus. When a cart is used, use caution when moving the cart/apparatus combination to avoid injury from tip-over.
- 13) Unplug this apparatus during lightning storms or when unused for long periods of time.
- 14) Refer all servicing to qualified service personnel. Servicing is required when the apparatus has been damaged in any way, such as power-supply cord or plug is damaged, liquid has been spilled or objects have fallen into the apparatus, the apparatus has been exposed to rain or moisture, does not operate normally, or has been dropped.



NOTE: The socket-outlet shall be installed near the equipment and shall be easily accessible.

SAVE THESE INSTRUCTIONS

CONTENTS

| | |
|---|------------|
| 1. Important notes | 73 |
| 1.1 Looking after the product | 73 |
| 1.2 Notes on floppy disks | 73 |
| 1.3 Notes about the manual | 74 |
| 2. Control central unit | 75 |
| 3. Switching on and Main video page | 77 |
| 4. Functions for controlling the organ's voices | 78 |
| 4.1 Regulating the voice volumes | 78 |
| 4.2 Regulating the sound generation parameters | 79 |
| 4.3 Selecting and regulating the Orchestra voices | 84 |
| Selecting the voice | 84 |
| Setting the parameters | 84 |
| 5. Organ general settings | 85 |
| 5.1 Setting the tremulants | 86 |
| 5.2 Selecting the type of reverb | 87 |
| 5.3 Keyboards general settings | 89 |
| 5.4 Setting the equalizer | 91 |
| 5.5 Setting the Antiphonal outputs | 91 |
| 6. Setting up the MIDI interface and audio outputs | 96 |
| 6.1 Regulating the display contrast | 96 |
| 6.2 Setting the audio signals on the rear outputs | 96 |
| Volumes | 97 |
| Delay times | 98 |
| Equalizers | 99 |
| 6.3 MIDI functions | 100 |
| What MIDI is | 100 |
| The Prestige MIDI settings | 101 |
| Selecting the channels | 102 |
| Setting the filters | 103 |
| Program Change message transmission | 104 |
| Setting the MIDI velocity | 105 |
| MIDI note code transposition | 106 |
| 6.4 Setting the rear audio outputs | 106 |
| Short introduction to the wind-chests of pipe organs | 107 |
| Simulating wind-chests with the Prestige | 108 |
| 7. Floppy disk and file management functions | 112 |
| 7.1 Displaying the contents of floppy disks | 113 |
| 7.2 Copying whole floppy disks | 113 |
| 7.3 Formatting floppy disks | 115 |
| 7.4 Displaying floppy disk general parameters | 115 |

| | |
|---|------------|
| 7.5 Saving the organ's memories and settings on disk | 116 |
| 7.6 Loading the organ's memories and settings saved on disk..... | 118 |
| 7.7 Copying individual files | 119 |
| 7.8 Renaming files | 121 |
| 7.9 Deleting files | 122 |
| 7.10 File information | 123 |
| 7.11 Error messages - Disk menu | 124 |
| 8. Sequencer | 126 |
| 8.1 Recording a performance | 126 |
| First recording | 126 |
| Multidubbing recording | 128 |
| 8.2 Playing back a performance | 130 |
| 8.3 Switching on and setting the metronome | 131 |
| 8.4 Error messages - Sequencer section | 131 |
| 9. Appendix | 133 |
| 9.1 Voice Local Off | 133 |
| 9.2 Factory Setting | 133 |
| 9.3 Updating the firmwares | 134 |
| Updating the Operating System firmware | 134 |
| Updating the Sound Driver firmware | 135 |
| Error messages - Firmware upgrade | 136 |
| 9.4 Checking the releases of the firmware packages installed in the organ | 137 |

1. IMPORTANT NOTES

1.1 LOOKING AFTER THE PRODUCT

- Do not apply excessive force to the organ's structures or the controls (knobs, stops, push-buttons, etc.).
- When possible, do not place the instrument close to units which generate strong interference, such as radios, TVs, computer videos, etc.
- Do not place the organ close to heat sources, in damp or dusty places or in the vicinity of strong magnetic fields.
- Do not expose the instrument to direct sunlight.
- Never insert foreign bodies inside the instrument or pour liquids of any kind into it.
- For cleaning, use only a soft brush or compressed air; never use detergents, solvents or alcohol.
- Always use good quality screened cables for connection to amplification or diffusion systems. When disconnecting cables from sockets, always take hold of the connector and not the cable itself; when winding cables, do not knot or twist them.
- Before making the connections ensure that the other units (especially amplification and diffusion systems) you are about to connect are switched off. This will prevent noisy or even dangerous signal peaks.
- If the organ is to be out of use for lengthy periods, disconnect the plug from the power socket.

1.2 NOTES ON FLOPPY DISKS

- Use only good quality floppy disks.
- Do not extract the floppy disk when reading or writing operations are in progress (when the LED on the drive is on); this may damage the head and the magnetic medium.
- Use only 3.5" DD and HD (720Kbyte and 1.44Mbyte) floppy disks formatted to the MS-DOS standard.
- Take good care of your floppy disks and do not place them close to heat sources or magnetic fields (computer videos, loudspeakers, etc.), or in damp or dusty places.
- The manufacturer does not accept any liability for damage to the floppy disk drive in case of use of damaged floppy disks.

1.3 NOTES ABOUT THE MANUAL

- Take good care of this manual.
- This manual is an integral part of the instrument. The descriptions and illustrations in this publication are not binding.
- While the instrument's essential characteristics remain the same, the manufacturer reserves the right to make any modifications to parts, details or accessories considered appropriate to improve the product or for requirements of a constructional or commercial nature, at any time and without undertaking to update this publication immediately.
- All rights reserved; the reproduction of any part of this manual, in any form, without the manufacturer's specific written permission is forbidden.
- All the trademarks referred to in this manual are the property of the respective manufacturers.
- Please read all the information carefully, so that you obtain the best performance and will from your instrument.
- The codes or numbers in square brackets ([]) indicate the names of the buttons, sliders, trimmers and connectors on the instrument. For example, [ENTER] refers to the ENTER button.
- The illustrations and display pages are purely guideline and may differ from those actually shown on the display.

1. **Display:** display of 40 characters on two lines for display of all the video pages relating to the organ's functions.
2. **Menu selection buttons:** these buttons allow you to select the four display function menus, as follows:
 - [VOICES] (chap. 4): voice adjustment parameters.
 - [SET-UP] (chap. 5): organ general settings (tremulant and reverb effects, equalizer, etc.)
 - [MIDI & UTILITY] (chap. 6): settings relating to the MIDI interface and rear outputs.
 - [DISK] (chap. 7): functions for the management of floppy disks and the files saved on them.
3. **MIDI TO Section:** this section contains the buttons used to activate the transmission of MIDI note codes on the A and B channels of each manual and the pedal board. The LED of each button displays the status of transmission on the relative MIDI channel as follows:
 - LED on: note code transmission enabled
 - LED off: note code transmission disabled
4. **VOLUMES Section:** these controls allow you to adjust the organ's individual volumes, as follows:
 - [PEDAL]: pedal board volume.
 - [MAN. I]: first manual volume.
 - [MAN. II]: second manual volume.
 - [MAN. III]: third manual volume (in 3-manuals versions only)
 - [ORCH.]: volume of the Orchestra voices (not featured on Prestige 20).
 - [REVERB]: reverb effect level.
 - [GENERAL]: the organ's general volume.
5. **Sequencer:** this section contains the buttons for control of the multitrack sequencer incorporated in the Prestige.
 - [PLAY]: this button allows playback of the MIDI sequences recorded.
 - [RECORD]: button for starting a recording session.
 - [METRONOME]: press quickly to activate the audio metronome; press for a few moments to recall the metronome setting video page.
 - [START-STOP]: starts / stops recording or playback of the MIDI sequence.

See chap. 8 for a complete description of sequencer functions.
6. **Display function control buttons:** these buttons allow you to move the cursor (identified by the flashing display field), set values, select video pages and confirm or reject prompts from the system.
 - [VALUE]: rotary encoder for setting parameters.
 - **CURSOR** [▲], [▼], [◀], [▶]: buttons used to move the cursor around within the display video pages. The [▲] and [▼] buttons have LEDs which come on to indicate the availability of a video page before and/or after the one displayed, respectively. Press the relative button to display the video page you require.
 - [ENTER]: button for displaying the content of functions or confirming any system prompts.
 - [EXIT]: button for exiting the current video page or rejecting any system prompts.

3. SWITCHING ON and MAIN VIDEO PAGE

When the organ is switched on using the [POWER] switch on the rear panel, the instrument becomes operational after a few seconds, during which all the amplification circuits are activated and the internal systems are configured.

After the switch-on procedure is complete, the main video page will be displayed:

```
ENSEMBLE:2      TEMPERAMENT:Equal
TUNING:0
```

containing the following parameters:

- **ENSEMBLE:** this parameter can be used to set eight levels of natural tiny differences in pitch between one organ pipe and another, in order to simulate the tuning error that occurs in the organ's pipes due to wear over time and variations in temperature. The values range from – (pipes perfectly tuned) to **8** (maximum pitch instability).
- **TEMPERAMENT:** this parameter allows the selection of a series of historic temperaments of different eras and national origins. You can choose from **EQUAL**, a temperament with perfect tuning, and the classical **MEANTONE**, **CHAUMONT**, **WERCKMEISTER**, **KIRNBERGER**, **PYTHAGOREAN**, **VALLOTTI** and **KELLNER** temperaments.
- **TUNING:** allows adjustment of the fine tuning of the instrument within a range of +/- 1/2 semitone, with setting by hundredths of a semitone.

N.B.

The organ should not be switched off and back on in rapid succession as this may damage the internal systems, especially the power supply and amplification circuits.

After the instrument is switched off, it is best to wait at least 15 seconds before switching it back on.

4. FUNCTIONS FOR CONTROLLING THE ORGAN'S VOICES

The menu containing the functions for controlling the instrument's church organ voices can be recalled by pressing the [VOICES] button. The video page displayed is as follows:

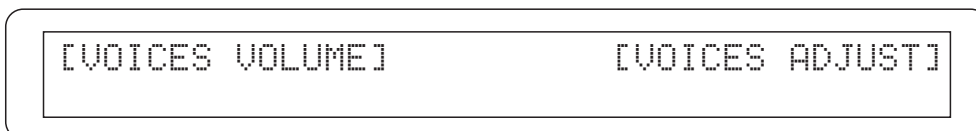

allowing you to recall the following functions:

- **VOICES VOLUME:** regulates the volume of each individual voice.
- **VOICES ADJUST:** regulates the sound generation parameters for each individual voice.

To recall a function, place the cursor on the field required using the [CURSOR] keys and press [ENTER].

Otherwise, press the [VOICES] or [EXIT] buttons to return to the main video page. You can also display another menu immediately by pressing the relative button in the MENU section of the central control unit.

4.1 REGULATING THE VOICE VOLUMES

The VOICES VOLUME function allows you to adjust the volume of each individual voice in a range from -12 dB to +6 dB. Each modification is saved immediately and is audible in real time, making it easier for the user to obtain the setting required.

The volume settings (of all the voices) can also be saved on a floppy disk using the FILE SAVE function (see point 7.5) to allow them to be reloaded as required.

To recall this function, select the VOICES VOLUME option from the VOICES menu; the display will show:

Prestige 100 - 80:

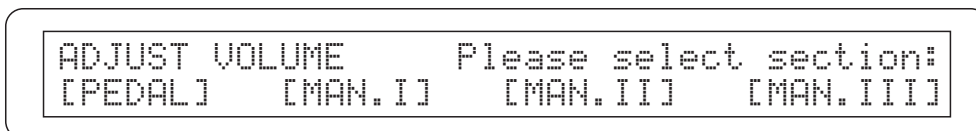

Prestige 70 - 60 - 50 - 40 - 20:

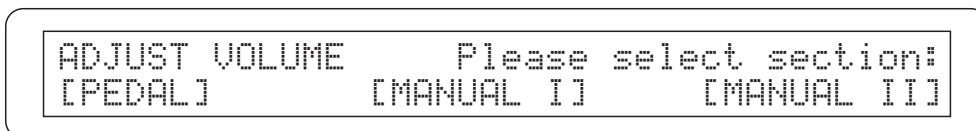

Now use the CURSOR [◀] and [▶] keys to move the cursor and [ENTER] to confirm in order to select the manual or pedal board containing the voice(s) the volume of which you wish to regulate. The display shows the first six voices and their current volumes:

```
Prinzi16:+2 CtBomb.32:0 CtBourd32:+3
Oktaveba8:0 Bombard16:-2 Subbass16:0
```

To set the new value (expressed in dB on the display), locate the cursor on the voice required using the [CURSOR] buttons or its draw-stop or register on the panel, and use the [VALUE] encoder to make the setting.

Once you have made all the changes you require, press [EXIT] to return to display of the VOICES menu.

4.2 REGULATING THE SOUND GENERATION PARAMETERS

One of the Prestige organ's most interesting characteristics is the capability for modifying the sound generation parameters **of every single voice** provided in the organ.

As for all the other VOICES menu functions, all the changes made to the setting parameters are audible in real time, are saved immediately and can be saved on a floppy disk using the FILE SAVE function (see point 7.5).

To recall this function, use the [CURSOR] and [ENTER] buttons to select the VOICES ADJUST field in the VOICES menu; the display will show:

Prestige 100 - 80:

```
VOICES ADJUST      Please select section:
[PEDAL]           [MAN. I]           [MAN. II]           [MAN. III]
```

Prestige 70 - 60 - 50 - 40 - 20:

```
VOICES ADJUST      Please select section:
[PEDAL]            [MANUAL I]           [MANUAL II]
```

Now use the [CURSOR] and [ENTER] buttons again to select the section of the organ containing the voice you wish to modify.

```
Prinzi16      Attack:2      ReleaseDetune:3
               Color:-3      Panning:C->R C#->L
```

As you can see, the first voice of the chosen manual or the pedal board appears in the top left-hand corner of the screen. The field is pre-selected, so you can move the [VALUE] encoder to scroll through all the section's voices. The voice can also be recalled using its draw-stop or register on the panel.

Together with the selected voice, the screen shows the first four parameters for modification, which are:

- **ATTACK:** adjusts the voice's attack time, i.e. the time it takes to reach the maximum volume value, on a scale of 8 values. Set 0 for the minimum attack time and 8 for the maximum time. Note that the scale of 8 values cannot be associated to fixed time values, since this parameter depends on the type of voice being modified (the Plenum, for example, has a shorter attack time than a Flute 16') and the Time Tracking of the keyboard, which means that attack times are shorter in the upper than in the lower part.
- **RELEASE DETUNE:** adjusts the variation in tuning when the note is released compared to the value with the note pressed, on a scale of 8 values. Here again, fixed values of hundredths of a semitone cannot be associated to the values shown on the screen, since the modification depends on the voice and the part of the keyboard being played. Set 0 for the minimum change in tuning and 8 for the maximum change.
- **COLOR:** sets the voice's brilliance in a range of values from -8 (maximum enhancement of the low components, maximum attenuation of the high components) to +8 (maximum attenuation of the low components, maximum enhancement of the high frequencies).
- **PANNING:** adjusts the voice's stereophonic distribution over the Left and Right channels of the organ's internal amplification system by means of the following settings:

Solo Left:

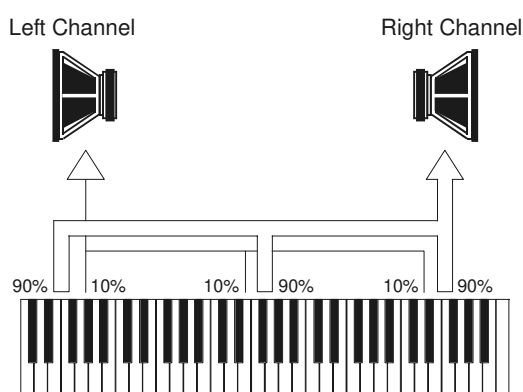

- 90% on left channel
- 10% on right channel

Solo Right:

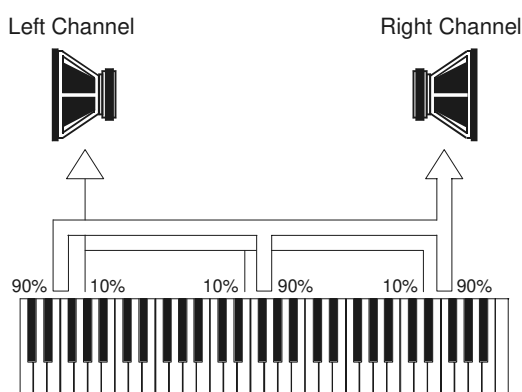

- 10% on left channel
- 90% on right channel

Left&Right:

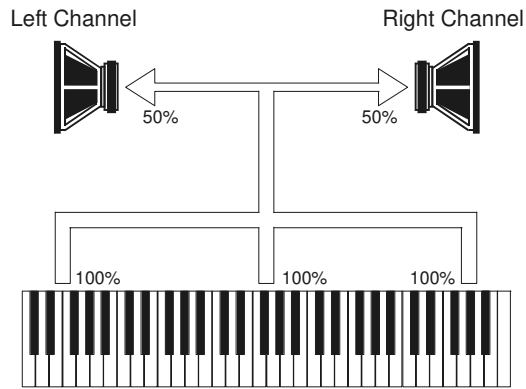

- 50% on left channel
- 50% on right channel

Left→Right→Left:

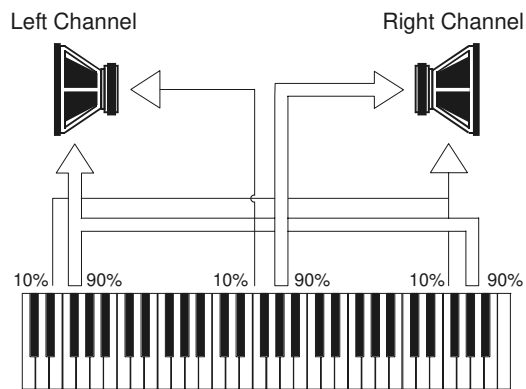

- 90% on left channel, 10% on right channel in the low part of the keyboard.
- 10% on left channel, 90% on right channel in the central part of the keyboard.
- 90% on left channel, 10% on right channel in the high part of the keyboard.

Right→Left→Right:

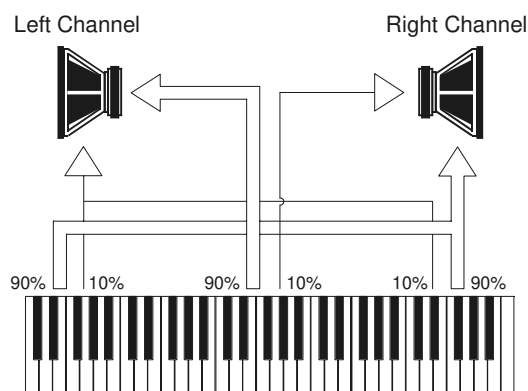

- 10% on left channel, 90% on right channel in the low part of the keyboard.
- 90% on left channel, 10% on right channel in the central part of the keyboard.
- 10% on left channel, 90% on right channel in the high part of the keyboard.

Left→Right:

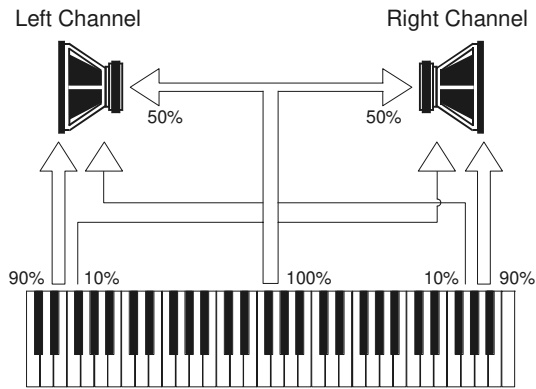

- 90% on left channel, 10% on right channel in the low part of the keyboard.
- 10% on left channel, 90% on right channel in the high part of the keyboard.

Right→Left:

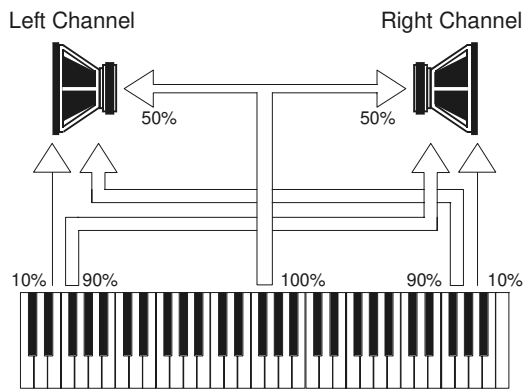

- 10% on left channel, 90% on right channel in the low part of the keyboard.
- 90% on left channel, 10% on right channel in the high part of the keyboard.

C→Left, C#→Right:

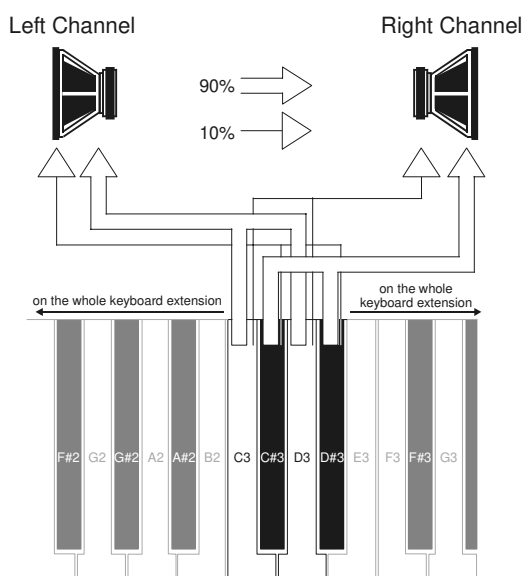

- 90% on left channel 10% on right channel for the notes C, D, E, F#, G#, A#
- 10% on left channel, 90% on right channel for the notes C#, D#, F, G, A, B

C→Right, C#→Left:

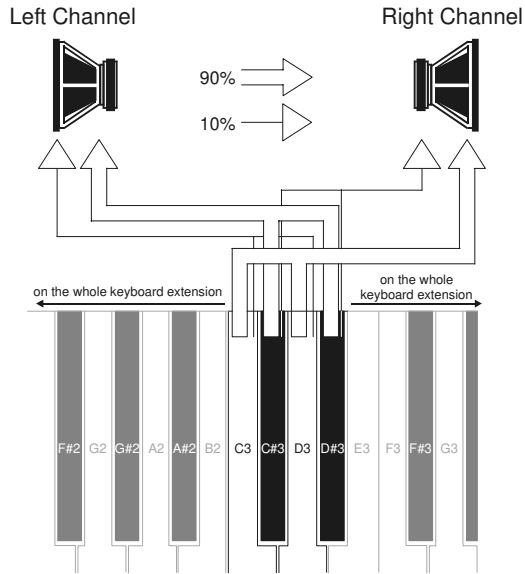

- 10% on left channel 90% on right channel for the notes C, D, E, F#, G#, A#
- 90% on left channel, 10% on right channel for the notes C#, D#, F, G, A, B

N.B.

The *PANNING* parameter settings also affect the distribution of the signals on the [ANTIPHONAL OUT] outputs since, as explained in point 5.5, in these outputs the audio signal corresponds to the internal stereophonic panorama.

Now the CURSOR [▼] button can be pressed to display the parameters relating to the KEYBOARD SCALING:

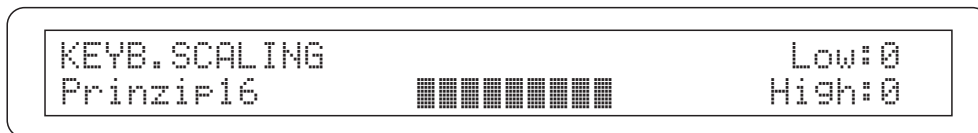

This parameter allows you to set the volume scaling, for the selected voice, throughout the keyboard range. The setting parameters are the following:

- **LOW:** regulates the attenuation (negative values) or increase (positive values) of the volume in the low part of the keyboard.
- **HIGH:** regulates the attenuation (negative values) or increase (positive values) of the volume in the high part of the keyboard.

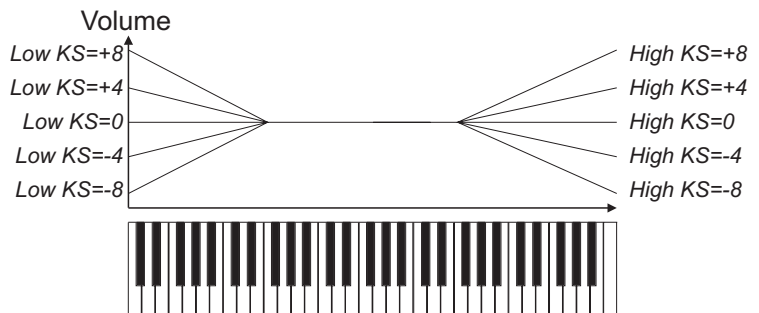

Finally, press [EXIT] to exit the function and save the settings made.

4.3 SELECTING AND REGULATING THE ORCHESTRA VOICES

SELECTING THE VOICE

Each Orchestra voice can be selected at will from the 128 available in the GM standard. To make the selection, keep the bottom of the Orchestra register you wish to replace pressed for a few moments; the first video page, for selecting the group of instruments, is displayed:

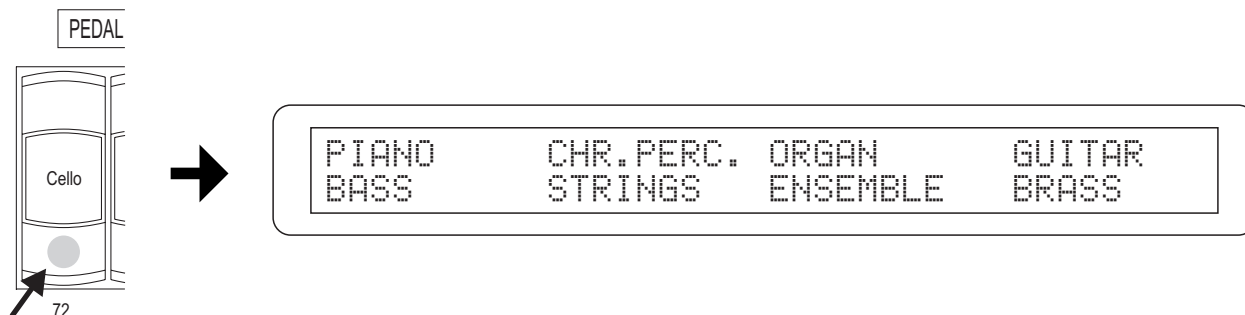

use the ([▲], [▼], [◀] and [▶]) cursor keys to select the group you require and press [ENTER] to display the voices it comprises:

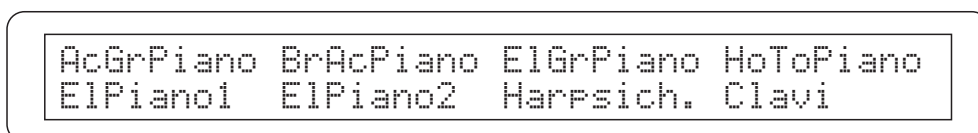

use the cursor keys again and press [ENTER] to activate the voice.

SETTING THE PARAMETERS

To set the parameters dedicated to the Orchestra voices, keep the top part of the register of the Orchestra voice you wish to adjust pressed for a few moments:

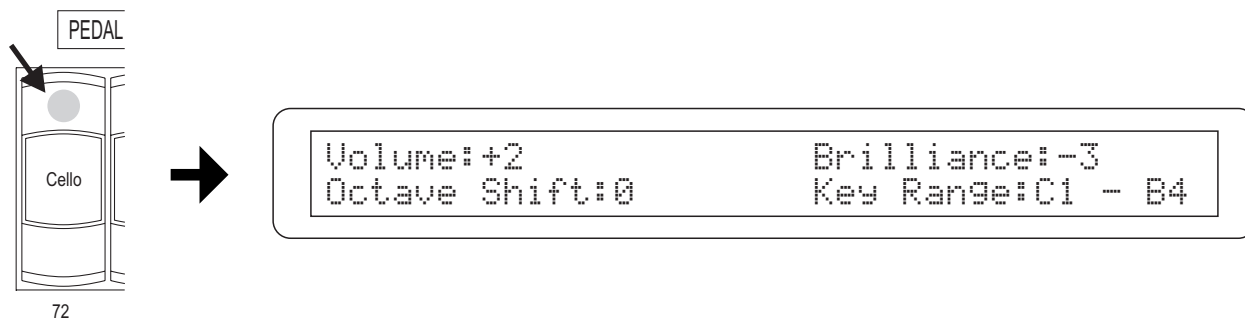

containing the following parameters:

- **VOLUME:** reduces (negative values) or increases (positive values) the volume of the voice.
- **BRILLIANCE:** reduces (negative values) or increases (positive values) the brilliance of the voice.
- **OCTAVE SHIFT:** transposes the notes played with the voice up or down one octave.

- **KEY RANGE:** sets the section of the manual on which the voice will be played.
The first value on the left is the bottom note of the section of the manual, and the second value the highest note.

Here again, after making the settings you require, press [EXIT] to save all the settings and return to display of the previous video page.

5. ORGAN GENERAL SETTINGS

Press the [SET-UP] button in the MENU section of the central control unit to access the organ's general settings. The video page displayed is as follows:

Prestige 100 - 80 - 70 - 60:

```
[TREMULANT] [REVERB] [KEYBOARDS SETTING]
[INT.EQUALIZER] [ANTIPH.OUT]
```

Prestige 50 - 40 - 20:

```
[TREMULANT] [REVERB] [KEYBOARDS SETTING]
[INTERNAL EQUALIZER]
```

In versions of the organ equipped with the Yamaha AFC reverb, the SET-UP menu consists of two video pages:

Prestige 100 - 80 - 70 - 60:

```
[TREMULANT] [REVERB] [KEYBOARDS SETTING]
[INTERNAL EQUALIZER]
```

```
[EXTERNAL ANTIPHONAL OUTPUTS SETTING]
[AFC EFFECT CALIBRATION]
```

Prestige 50:

```
[TREMULANT] [REVERB] [KEYBOARDS SETTING]
[INTERNAL EQUALIZER]
```

```
[AFC EFFECT CALIBRATION]
```

The selection fields are as follows:

- **TREMULANT:** setting of the Tremulants for each manual.
- **REVERB:** selection of the type of reverb required. Balancing between internal and AFC reverb (in versions equipped with AFC reverb only).
- **KEYBOARDS SETTING:** setting of the general parameters relating to the manuals and pedal board.
- **INTERNAL EQUALIZER / INTERNAL AMPLIFICATION EQUALIZER:** setting of the organ's internal equalizer.
- **ANTIPHONAL OUT / EXTERNAL ANTIPHONAL OUTPUTS SETTING:** setup of the [ANTIPHONAL OUT] rear outputs (not available in Prestige 50, 40 and 20).
- **AFC EFFECT CALIBRATION:** automatic calibration of the AFC reverb (not available in Prestige 40 and 20).

To select the function of choice, place the cursor on the field required using the [CURSOR] buttons and press [ENTER].

Otherwise, press [EXIT] or [SET-UP] to exit the current menu and return to the main video page. Otherwise, press the button of another menu for direct access to the function menu required.

All the changes made to the parameters in these functions are audible in real time, are saved immediately and can be saved on a floppy disk using the FILE SAVE function (see point 7.5).

4.1 SETTING THE TREMULANTS

In pipe organs it is of fundamental importance for the air pressure to be constant to obtain an even, "sustained" sound.

However, a number of mechanical devices were introduced in the past to generate more or less noticeable periodic variations in the air flow.

These variations produced a "tremulous" effect on the sound, which made a number of solo stops (such as the Vox Humana) more pleasant on the ear, and gave added expression to the reed stops. Use the [TREMULANT] draw-stops / registers on the organ's panels to enable or disable this effect.

The TREMULANT function can be used to set the speed and modulation depth of the tremulants for each manual.

After the TREMULANT field is selected in the SET-UP menu, the display will show the video page:

Prestige 100 - 80:

| | | | |
|-------------|--------|---------|----------|
| TREMULANT: | Man. I | Man. II | Man. III |
| Depth/Speed | 16/16 | 16/16 | 16/16 |

Prestige 70 - 60 - 50 - 40 - 20:

| | | |
|-------------|----------|-----------|
| TREMULANT: | Manual I | Manual II |
| Depth/Speed | 16/16 | 16/16 |

containing the current values of the **Depth** (modulation depth) and **Speed** (modulation speed) parameters of the tremulant of the manual specified on the top line.

As the display indicates, the number on the left of the “/” symbol is the Depth and the number on the right the Speed.

To set the values use the [CURSOR] buttons to move the cursor and the [VALUE] encoder.

Once you have made all the settings you require, press [EXIT] to return to display of the SET-UP menu and save the new settings.

N.B.

The Depth and Speed parameters can be saved with different values in each general and divisional memory, in the Tutti, and in each step of the Crescendo. To do this, saving must be enabled using the Keyboards Setting function described in point 5.3.

5.2 SELECTING THE TYPE OF REVERB

Reverberation is the result of a series of sound reflections propagated inside an enclosed environment. The order and value of each reflection depend to a very great extent on a large number of factors which come into play within any one room, such as the size of the room in which the phenomenon takes place, the nature of the materials of which it is made and the objects it contains, the listener’s position, etc.

The digital signal processors incorporated in the Prestige organs are able to artificially re-create the complex reverberations that naturally occur in the types of building where pipe organs are normally installed, and thus generate the right reverb effect to complete the instruments’ excellent timbre qualities.

The purpose of the REVERBERATION TYPE function in the SET-UP menu is to allow you to select the type of reverb effect, ranging from a large church with strong reverb and many reflections to a small room with very short, muffled reverb.

You may use this function to select eight different types of reverb effect. You can then use the [REVERB] trimmer in the central control section to regulate the level of reverb effect required.

To select the reverb required, select the REVERB field in the SET-UP menu and press [ENTER]:

| |
|-------------------------------|
| REVERBERATION type: Cathedral |
|-------------------------------|

The possible selections are:

- **CATHEDRAL**
- **BASILICA**
- **GOTHIC CHURCH**
- **BAROQUE CHURCH**
- **ROMANIC CHURCH**
- **MODERN CHURCH**
- **PARISH**
- **CAPPELLA**

Use the encoder to select the type of reverb and press [EXIT] to save the selection and return to display of the SET-UP menu.

N.B.

The organ's internal reverb also affects the input signals reaching the [INPUT] connectors on the rear panel and underneath the manuals.

ORGAN VERSION EQUIPPED WITH AFC REVERB UNIT

The AFC (Active Field Control) unit developed by the Yamaha Corporation is an innovative reverb system which uses the latest electro-acoustic technologies to make the characteristics of the reverb effect, such as the strength, spaciousness and reflection of the sound, as effective and natural as possible.

In order to generate the reverb, the AFC monitors the acoustic response of the building where the organ is installed and adapts the effect's characteristics accordingly. Thanks to this, the organ can be used in large buildings without the undesirable effects this type of context may cause, or on the other hand it can be placed in a very small room and used to produce exactly the same reverb as in a large concert hall.

In versions of the organ equipped with the AFC system, as well as selecting the reverb type you may also adjust the balance between the internal and AFC reverbs. The video page displayed is as follows:

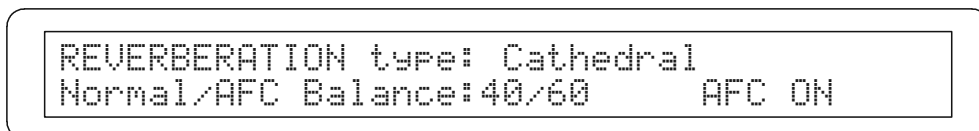

The NORMAL/AFC BALANCE parameter regulates the balance between the two types of reverb, while the field on the right displays the current status of the AFC system, as follows:

- AFC ON: AFC system active
- AFC BUSY: the AFC system is at work and processing data. The reverb is not currently available. Wait for "AFC ON" to appear on the screen.
- AFC OFF: AFC system deactivated.

Once you have made all the settings you require, press [EXIT] to return to display of the SET-UP menu and save the new settings.

5.3 KEYBOARDS GENERAL SETTINGS

The KEYBOARDS SETTING function, recalled using the option of the same name in the SET-UP menu, contains four different organ general setting parameters.

The first of these is the RANKS DISTANCE:

Prestige 100 - 80:

```
RANKS DISTANCE
Ped:15   Man.I:8   Man.II:10  Man.III:8
```

Prestige 70 - 60 - 50 - 40 - 20:

```
RANKS DISTANCE
Pedal:15   Manual I:8   Manual II:10
```

This parameter allows a delay time to be set for generation of the voice sound in relation to the moment when a note is pressed on the keyboard, for each individual manual and the pedal board.

In almost all the original pipe organs installed in large churches, the pipe wind-chests are some distance from the organ and the organist who is playing it, sometimes even in special rooms. There are cases in which the wind-chests of one division are behind the altar, while those of another division are at the entrance to the church. Obviously, this distance generates some delay between the moment when the organist depresses a key and when he starts to hear the sound of the pipes.

This parameter allows simulation of a distance from 0 to 31 metres between the organ and the pipe wind-chests.

The video contains four fields, corresponding to the organ's sections, while the bottom line contains the distance in metres simulated between the organ and the wind-chests.

Now the CURSOR [▼] button can be pressed to display the PISTON COMBINE and KEYBOARDS INVERSION parameters.

Bearing in mind that the way in which the PISTON COMBINE function works depends on the model of organ being used, we will obtain:

- in Prestige 100 and 80

```
MAN.I/MAN.II KEYBOARDS INVERSION:disable
MAN.II/PEDAL PISTON COMBINE:disable
```

The MAN.II/PEDAL PISTON COMBINE function allows the memories of the second manual to be “coupled” to those of the pedal board. This means that when a manual II memory is recalled, the same memory will also be automatically activated for the pedal board.

- in Prestige 70 and 60

```
KEYBOARDS INVERSION:disable  
MAN.I/PEDAL PISTON COMBINE:disable
```

In this case the MAN.I/PEDAL PISTON COMBINE function allows the memories of the first manual to be “coupled” to those of the pedal board. This means that when a manual I memory is recalled, the same memory will also be automatically activated for the pedal board.

- in Prestige 50, 40 and 20

```
KEYBOARDS INVERSION:disable
```

In these models the function is not available.

The MAN.I/MAN.II KEYBOARDS INVERSION (in Prestige 100 and 80) and KEYBOARDS INVERSION (Prestige 70, 60, 50, 40 and 20) functions, on the other hand, allow the positions of Man.I and Man.II to be reversed.

To set these two parameters simply locate the cursor beside the display option and use the [VALUE] encoder to select **enable** to activate it or **disable** to deactivate it.

In addition, the status of these two settings is displayed by the Leds [I/II KEYB. INV.] (Prestige 100 and 80), [KEYB. INV.] (Prestige 70) or [K. INV.] (Prestige 60, 50, 40 and 20) and [II/PD PIST. COMB.] (Prestige 100 and 80), [I/P PIST. COMB.] (Prestige 70) or [P. COMB.] (Prestige 60) on the central or right panel.

Now press the CURSOR [▼] button and the screen will show the last KEYBOARDS SETTING function, used to activate or deactivate saving of the Enclosed and Automatic Pedal in the general memories and the Depth and Speed parameters of **all** the tremulants in the general and divisional memories, the Tutti and each step of the Crescendo:

```
ENCLOSED, AUTOMATIC PEDAL AND TREMULANT  
DEPTH AND SPEED STORED IN MEMORIES:NO
```

Use the [VALUE] encoder to select **YES** to enable saving or **NO** to disable it.

NOTA

If saving of the Enclosed and Automatic Pedal is enabled using the parameter described above, pressing the Cancel button underneath the manuals does not switch these two functions off.

Now press [EXIT] to return to display of the SET-UP menu and save the settings.

5.4 SETTING THE EQUALIZER

The Prestige has its own internal graphic five-band equalizer allowing control of the character of the sound generated by the organ.

To display the setting video page, select the INT. EQUALIZER field (or INTERNAL EQUALIZER in the version with AFC) and press [ENTER]:

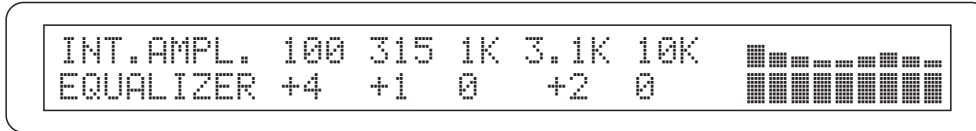

As can be seen, the top of the video page contains the central frequencies of the five bands on which the equalizer operates.

The bottom line allows regulation of the attenuation (negative values) or enhancement (positive values) of the signal in a range of +/- 12 dB.

A graphic indication of the equalizer is also displayed on the right of the screen, in real time.

Here again, after making the settings you require, press the [EXIT] button to save the modifications and return to display of the SET-UP menu.

5.5 SETTING THE ANTIPHONAL OUTPUTS

In the factory settings, the signals are distributed across the [ANTIPHONAL OUT] outputs as follows:

- in Prestige 100 and 80

- outputs [9] and [10]: church organ voices of Man.I and Man.III. Orchestra voices
- outputs [11] and [12]: Man.II and Pedal Board voices and inputs [INPUT]

- in Prestige 70 and 60

- outputs [9] and [10]: church organ voices of Man.II and Orchestra voices
- outputs [11] and [12]: Man.I and Pedal Board voices and inputs [INPUT]

- in Prestige 50, 40 and 20

The function is not available.

For each pair of outputs, the signals follow the stereophonic channelling set for the internal amplification system using the VOICES ADJUST Panning parameter (see also point 4.2) in the VOICE menu.

This means that if a voice is set to play on the amplifier Left channel (Panning parameter Solo Left setting), it will only be present on the left-hand Antiphonal output ([9] or [11]).

However, the ANTIPHONAL OUTPUTS SETTING function allows you to select other modes for use of the Antiphonal outputs, so that they transmit the general signal, the signal with reverb effect only, or both signals on two different pairs of outputs.

To display the setting video page, select the ANTIPH. OUT field (EXTERNAL ANTIPH. OUTPUTS SETTING in the version with AFC):

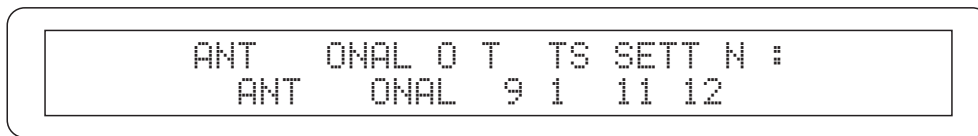

The meanings of the voices available are:

- **ANTIPHONAL (9-10-11-12):**

- **in Prestige 100 and 80**

- In this mode the Man.I and Man.III and Orchestra voice signals are present on outputs [9] and [10], while the Man.II, Pedal Board and input [INPUT] signals are present on outputs [11] and [12].

- **in Prestige 70 and 60**

- In this mode the Man.II and Orchestra voice signals are present on outputs [9] and [10], while the Man.I, Pedal Board and input [INPUT] signals are present on outputs [11] and [12].

- **REVERB OUT (9-10-11-12):** only the signal with reverb effects is present on all the [ANTIPHONAL OUT] outputs.
- **REVERB OUT (9-10) + GENERAL OUT (11-12):** with this setting, only the signal with reverb effect is present on outputs [9] and [10] while outputs [11] and [12] carry the organ general signal only.

Remember that in all three modes, the stereophonic distribution of the voices on the outputs is set by the Panning parameter of the VOICE ADJUST function.

However, the setup of the Antiphonal outputs is strictly dependent on the settings of the EXTERNAL OUTPUTS VOICES ROUTER function of the MIDI&UTILITY menu (see also point 6.4).

This function sets up all the rear panel outputs by means of 4 Presets supplied by the organ's producer in order to simulate the real wind-chests of pipe organs.

To do this, each voice is distributed across the rear outputs in a special way (for example, to simulate a Chromatic wind-chest).

However, outputs [9] and [10] or [11] and [12] may still be used for one or more voices; in this case the display options will change to:

- **ANTIPHONAL (9-10):** In this mode, the general organ signal is present on outputs [9] and [10]. Outputs [11] and [12] **only** carry the signal of the voices, in accordance with the settings of the EXTERNAL OUTPUTS VOICES ROUTER function.

- **ANTIPHONAL (11-12):** In this mode, the general organ signal is present on outputs [11] and [12]. Outputs [9] and [10] **only** carry the signal of the voices, in accordance with the settings of the EXTERNAL OUTPUTS VOICES ROUTER function.
- **REVERB OUT (9-10):** only the signal with reverb effect is present on outputs [9] and [10]. Outputs [11] and [12] **only** carry the signal of the voices, in accordance with the settings of the EXTERNAL OUTPUTS VOICES ROUTER function.
- **REVERB OUT (11-12):** only the signal with reverb effect is present on outputs [11] and [12]. Outputs [9] and [10] **only** carry the signal of the voices, in accordance with the settings of the EXTERNAL OUTPUTS VOICES ROUTER function.
- **GENERAL OUT (9-10):** In this mode, the general organ signal is present on outputs [9] and [10]. Outputs [11] and [12] **only** carry the signal of the voices, in accordance with the settings of the EXTERNAL OUTPUTS VOICES ROUTER function.
- **GENERAL OUT (11-12):** In this mode, the general organ signal is present on outputs [11] and [12]. Outputs [9] and [10] **only** carry the signal of the voices, in accordance with the settings of the EXTERNAL OUTPUTS VOICES ROUTER function.
- **RESERVED** all four [ANTIPHONAL OUT] outputs are used by the EXTERNAL OUTPUTS VOICES ROUTER function.

In this case it is not possible to select one of the configurations described above; to do this, another voice router Preset which does not use all the Antiphonal outputs must be selected.

ANTIPHONAL OUTPUT CONNECTION EXAMPLES

ANTIPHONAL

ANTIPHONAL (9-10-11-12) on the display

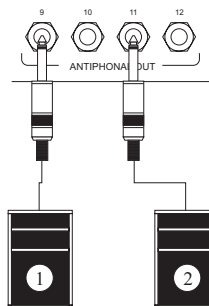

- ① **PRESTIGE 100 and 80:**
Here Man.I, Man.III and the Orchestra voices play (monophonic)
PRESTIGE 70 and 60:
Here Man.II and the Orchestra voices play (monophonic)

- ② **PRESTIGE 100 and 80:**
Here Man.II, the Pedal board and the inputs [INPUT] play (monophonic)
PRESTIGE 70 and 60:
Here Man.I, the Pedal board and the inputs [INPUT] play (monophonic)

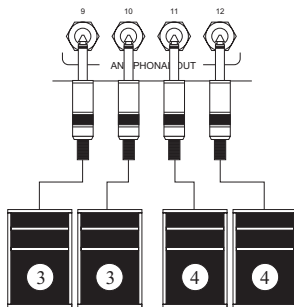

- ③ **PRESTIGE 100 and 80:**
Here Man.I, Man.III and the Orchestra voices play with stereophonic panning
PRESTIGE 70 and 60:
Here Man.II and the Orchestra voices play with stereophonic panning

- ④ **PRESTIGE 100 and 80:**
Here Man.II, the Pedal board and the inputs [INPUT] play with stereophonic panning
PRESTIGE 70 and 60:
Here Man.I, the Pedal board and the inputs [INPUT] play with stereophonic panning

ANTIPHONAL with Principal 16' directed to outputs [9] and [10]

ANTIPHONAL (11-12) on the display

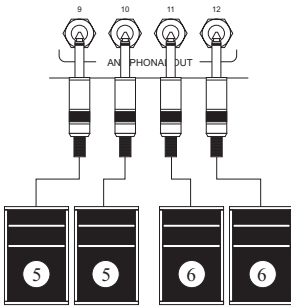

- ⑤ Here only the Principal 16' plays with stereophonic panning
- ⑥ Here the organ's general signal is present with stereophonic panning

REVERB OUT

REVERB OUT (9-10-11-12) on the display

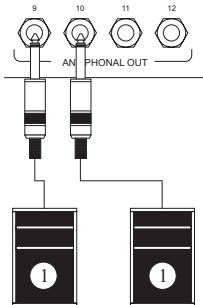

- ① Here only the reverb effect signal is present

REVERB OUT with Principal 16' directed to outputs [9] and [10]

REVERB OUT (11-12) on the display

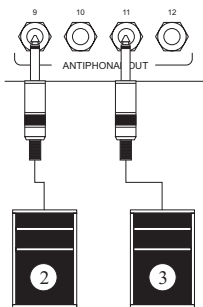

- ② Here only the Principal 16' plays (monophonic)
- ③ Here only the reverb effect signal is present

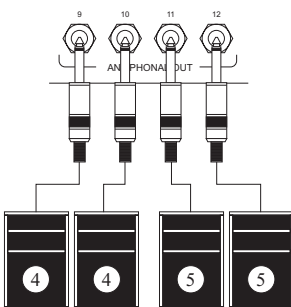

- ④ Here only the Principal 16' plays with stereophonic panning
- ⑤ Here only the reverb effect signal is present

REVERB OUT + GENERAL OUT

REVERB OUT (9-10) + GENERAL OUT (11-12) on the display

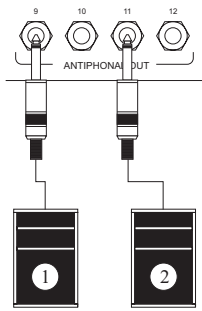

- ① Here only the reverb effect signal is present
- ② Here the organ's general signal is present (monophonic)

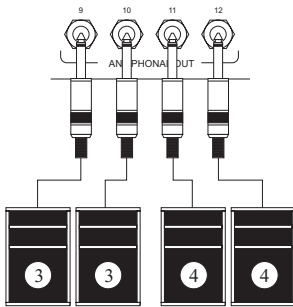

- ③ Here only the signal with reverb effect is present on two speakers
- ④ Here the organ's general signal is present (stereophonic)

REVERB OUT + GENERAL OUT with Principal 16' directed to outputs [9] and [10]

GENERAL OUT (11-12) on the display

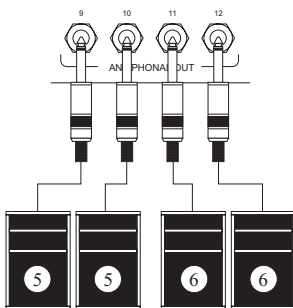

- ⑤ Here only the Principal 16' plays with stereophonic panning
- ⑥ Here the organ's general signal is present with stereophonic panning

6. SETTING UP THE MIDI INTERFACE AND AUDIO OUTPUTS

The MIDI&UTILITY menu contains all the setup functions of the organ's MIDI interface and the [MAIN OUT] ([OUTPUT] in Prestige 50, 40 and 20) and [ANTIPHONAL OUT] audio outputs. This menu also allows adjustment of the display contrast.

To access these functions, press the [MIDI&UTILITY] button. The video page displayed is as follows:

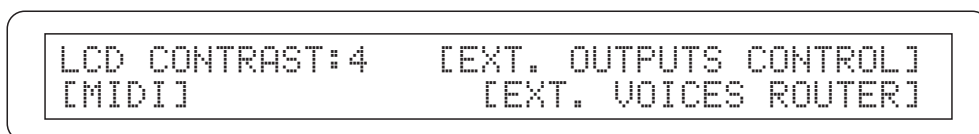

comprising the following selection fields:

- **LCD CONTRAST:** regulates the display contrast.
- **EXTERNAL OUTPUTS CONTROL:** adjustment of the levels, delays and equalizers of every single rear panel [MAIN OUT] and [ANTIPHONAL OUT] output.
- **MIDI:** MIDI settings.
- **EXTERNAL VOICES ROUTER:** selection of the Presets for setup of the rear audio outputs.

As for the other menus, use the [CURSOR] and [ENTER] buttons to select the function required. Otherwise, press [EXIT] to exit the MIDI&UTILITY menu and return to display of the main video page.

6.1 REGULATING THE DISPLAY CONTRAST

The Prestige's display has a contrast adjustment function allowing the maximum visibility to be obtained for the organist's performing angle.

The setting can be made directly from the MIDI&UTILITY menu by locating the cursor on the LCD CONTRAST field and setting the value using the [VALUE] encoder.

6.2 SETTING THE AUDIO SIGNALS ON THE REAR OUTPUTS

Another important feature of Prestige series organs is the presence of audio parameters allowing control of the signal present on each [MAIN OUT] ([OUTPUT] in Prestige 50, 40 and 20) and [ANTIPHONAL OUT] output (the latter not provided in the 50, 40 and 20 models) on the rear panel.

The adjustment of each output's audio parameters allows even more realistic, accurate simulation

of the original wind-chests.

Moreover, the possibility of real-time control of the acoustic response of each speaker connected, at any moment, guarantees an extremely quick, effective sound setup.

Each output has its own volume, delay and equalisation controls; these parameters are all found in the EXTERNAL OUTPUTS CONTROL function.

To activate this function, select the EXT. OUTPUTS CONTROL field in the MIDI&UTILITY menu with the aid of the usual selection buttons. The display will show the page:

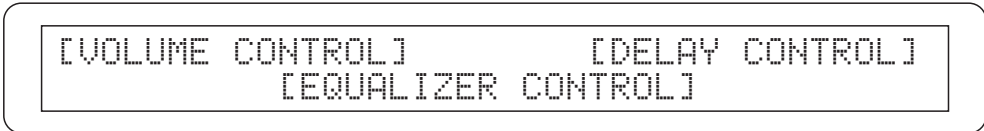

This submenu allows you to recall the following functions:

- **VOLUME CONTROL:** regulates the volume of each individual output.
- **DELAY CONTROL:** regulates the delay times.
- **EQUALIZER CONTROL:** sets up the 5-band graphic equalizers for each individual output.

VOLUMES

To adjust the volumes of each individual [MAIN OUT] and [ANTIPHONAL OUT] output, select the VOLUME CONTROL field in the video page shown above and press [ENTER].

- Prestige 100, 80, 70 and 60

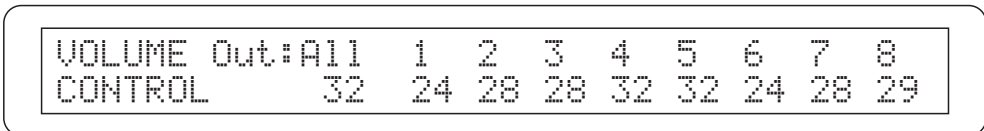

The video page contains an **ALL** field for setting a general level for the 12 outputs, then the individual levels of the first 8 ([MAIN OUT]) outputs, identified by the numbers on the top line of the video page.

To display the values of the four other ([ANTIPHONAL OUT]) outputs, press the CURSOR [▼] button.

- Prestige 50, 40 and 20

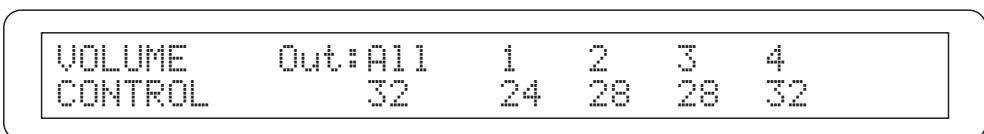

The video page contains an **ALL** field for setting a level general for the 4 [OUTPUT] outputs, then

the individual levels identified by the numbers on the top line of the video page.

Use the CURSOR [◀] and [▶] buttons to move the cursor and the [VALUE] encoder to make the setting.

All the levels can be set in a range of values from 1 to 32, with the following relative dB:

- 32: +12 dB
- 20: 0 dB
- 16: -4 dB
- 10: -10 dB
- 1: -19 dB

Naturally, intermediate signal level values will be obtained when values between these settings are shown on the display.

DELAY TIMES

Another important setting function for the rear outputs regards the delay times which can be applied to each output individually. A delay time is the time which passes between when the note is pressed on the keyboard and the start of transmission of the audio signal on the output.

This function allows simulation of different organ pipe distances, up to a maximum of 31 metres; the system will generate the correct delay for the distance set.

From the EXTERNAL OUTPUTS CONTROL submenu select the DELAY CONTROL field:

- Prestige 100, 80, 70 and 60

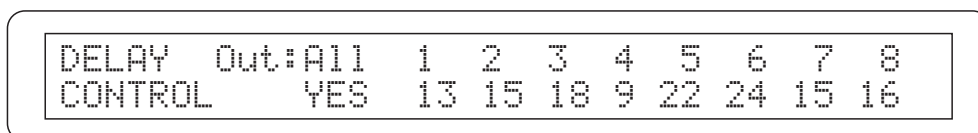

Like the previous video page, this screen also contains an **ALL** field: select **YES** to allow selection of the pipe distance (in a range from 0 to 31 metres) for each individual output, or select **NO** for distances automatically set at 0 for all the outputs. If YES is selected again, the values of the latest setting will be restored.

The first video page displays the distances for the first 8 ([MAIN OUT]) outputs, identified by the 8 numbers shown on the top line. To display the 4 other ([ANTIPHONAL OUT]) outputs, press the CURSOR [▼] button.

As usual, use the CURSOR [◀] and [▶] buttons to move the cursor and the [VALUE] encoder to regulate the value.

- Prestige 50, 40 and 20

```

DELAY      Out:All   1   2   3   4
CONTROL    YES     13  15  18  9

```

The video page contains an **ALL** field: select **YES** to allow selection of the pipe distance (in a range from 0 to 31 metres) for each individual output, or select **NO** for distances automatically set at 0 for all the outputs. If YES is selected again, the values of the latest setting will be restored.

The distances for the 4 ([MAIN OUT]) outputs, identified by the 4 numbers shown on the top line, are also displayed.

Use the CURSOR [◀] and [▶] buttons to move the cursor and the [VALUE] encoder to regulate the value.

EQUALIZERS

From the EXTERNAL OUTPUTS CONTROL submenu select the EQUALIZER CONTROL field:

```

OUT 1      100 315 1K 3.1K 10K  ████
EQUALIZER +4  +1  0  +2  0  ████

```

This video page allows you to set up the 5-band graphic equalizers available for each individual output.

The first field in the top right-hand corner indicates the output for which the equalisation values are being displayed. Use the [VALUE] encoder to select the 12 outputs (in Prestige 100, 80, 70 and 60) or the 4 [OUTPUT] outputs (in Prestige 50, 40 and 20).

Use the [▶] button to locate the cursor in the adjustment fields of the five operating bands for which the signal gain / attenuation can be set in a range of values from +8 dB to -8 dB.

A graphic indication of the equalizer being adjusted is also displayed on the right of the screen, in real time.

6.3 MIDI FUNCTIONS

WHAT MIDI IS

The MIDI (Musical Instrument Digital Interface) interface allows instruments of different makes and kinds to communicate with each other, using this very specific protocol of codes. This allows the creation of systems of MIDI instruments, offering much greater versatility and control than is possible with single instruments. To make this communication possible, all MIDI instruments have two or three 5-pin DIN connectors called:

- **MIDI IN:** The connector through which the instrument receives the MIDI data transmitted by other units.
- **MIDI OUT:** The connector through which the instrument sends the MIDI data it has generated to other units.
- **MIDI THRU:** This connector, not always provided on all instruments, is used for connecting several units in series, since it transmits the MIDI data exactly as they are received by the respective MIDI IN port.

Most instruments equipped with MIDI interface transmit MIDI messages which specify, for example, which note has been played and with what dynamic, by means of the MIDI OUT connector. If this connector is connected to the MIDI IN connector of another MIDI instrument, such as an expander, the second instrument will respond exactly to the notes played on the transmitter instrument.

The same type of information transfer is used for recording MIDI sequences. A computer or a sequencer can be used to record the MIDI data generated by the transmitter instrument. If these recorded data are sent back to the instrument, it automatically repeats the recorded performance.

MIDI is able to transmit a multitude of digital data by means of just one cable, and thus just one connector. This is thanks to the MIDI channels. There are 16 MIDI channels, and in a similar way as for radio communications in which two stations can only communicate if they are tuned to the same frequency (or channel), two MIDI instruments connected together are only able to communicate if the transmitter instrument channel is the same as the receiver instrument channel.

MIDI messages subdivide into channel messages and system messages. The following is a short description of these messages:

CHANNEL MESSAGES

NOTE ON

This message is transmitted when a note is pressed on the keyboard. Each Note On message contains the following information:

Note On: when a key has been struck;

Note Number: the key which has been pressed, and therefore the relative note played;

Velocity: note dynamic (i.e. the force applied when the key was struck).

Note messages are expressed as a number from 0 to 127, with middle C represented by number 60.

NOTE OFF

This message is transmitted when a key struck previously is released.

When it is received, the sound of the note relating to the key is switched off. Each Note Off message contains the following information:

Note Off: a key has been released;

Note Number: which key has been released;

Velocity: dynamic (i.e. how fast the note was released).

N.B.:

A Note On message with Velocity=0 is considered equivalent to a Note Off message. The Prestige sends the Note On message with Velocity=0.

PROGRAM CHANGE

This message is used to select the programs or sounds of the receiver instrument.

There is also a specific standard called General MIDI which describes which sound should be recalled for each Program Change received. This association is usually described by means of a table included in the user manual of the instrument which adopts the standard.

This message contains the following information:

Program Change: voice or program change;

Program Change Number: the number of the program or voice to be activated;

CONTROL CHANGE

These are control messages (often associated to trimmers or pedals) used to add expression to the performance, allowing you to set (and control in real time if necessary) voice parameters such as volume (CC n.7) or the position of the expression pedals (CC n.11), etc.

This message contains the following information:

Control Change: a controller has been adjusted

Controller Number: which controller has been adjusted

Controller Position: the position of the controller

SYSTEM MESSAGES

SYSTEM EXCLUSIVE

These messages can only be interpreted by an instrument made by the same producer as the transmitter device (in some cases only by the same model). They mainly relate to the instrument's sound generation and programming parameters. The Prestige uses these messages to control all the internal parameters and for switching the voices on and off.

REAL TIME

These messages are used for the real-time control of specific modules or functions of a connected instrument.

These messages include the Start, Stop, Pause/Continue and Clock commands. In the Prestige these messages are transmitted when the sequencer is used, as follows:

START: the sequencer has started to record or play back a MIDI sequence

STOP: the sequencer has been stopped

PAUSE / CONTINUE: the sequencer has been set in stop status

CLOCK: the sequencer speed

The Real Time messages also include the Active Sensing code, sent to keep the dialogue between two MIDI instruments alive. When the receiver instrument does not receive any MIDI data or the Active Sensing code in a time interval of about 300 milliseconds, it considers the MIDI connection to have been deactivated, so it switches off any notes still active. Remember that the transmission and reception of this message is optional, so not all instruments are equipped to handle it.

THE PRESTIGE MIDI SETTINGS

To access all the Prestige's MIDI settings, select the MIDI option in the MIDI&UTILITY menu and press [ENTER].

```
[CHANNELS] [FILTERS] [PROGRAM CHANGE]
[NOTES VELOCITY] [OCTAVE TRANSPOSER]
```

As you can see, a submenu is displayed containing the following functions:

- **CHANNELS**: MIDI transmission and reception channel selection.
- **FILTERS**: MIDI filter setting.
- **PROGRAM CHANGE**: Program Change message transmission.
- **NOTES VELOCITY**: setting of the MIDI dynamics of the manuals and pedal board.

- **OCTAVE TRANSPOSER:** transposes the notes transmitted by the [MIDI OUT] port in octaves.

Use the [CURSOR] and [ENTER] buttons to select the function required.

Otherwise, press [EXIT] to exit the MIDI menu and return to display of the MIDI&UTILITY menu.

SELECTING THE CHANNELS

The Prestige is able to transmit MIDI messages on two channels, called A and B, simultaneously for each section of the organ. This means that even if just one manual is played, the MIDI notes can be transmitted on two separate channels, offering the considerable advantage that two mono-voice sound modules, or two voices in a multi-voice expander, connected to the [MIDI OUT] port can be played simultaneously.

Naturally, the same applies to all MIDI channel messages envisaged by the MIDI protocol (Note, Control Change and Program Change).

The [MIDI TO] buttons in the central control unit activate or deactivate transmission of the MIDI note messages on the channels assigned to the manuals and the pedal board.

Operation of the MIDI TO buttons is described in point 4 chap. 1.

However, it is important to remember that the MIDI TO buttons only control transmission of MIDI notes, so even if the MIDI TO buttons are off, all the other MIDI messages are still transmitted.

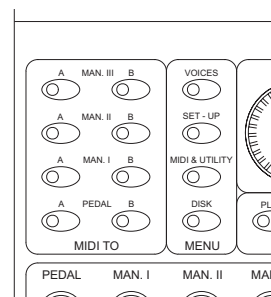

To set the MIDI A and B transmission channels, select the CHANNELS field in the MIDI submenu:

Prestige 100 - 80:

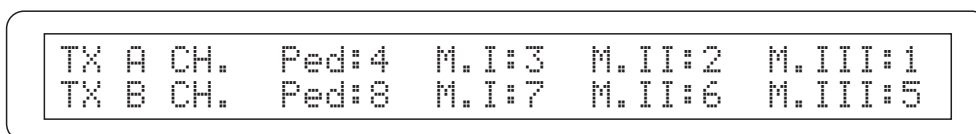

Prestige 70 - 60 - 50 - 40 - 20:

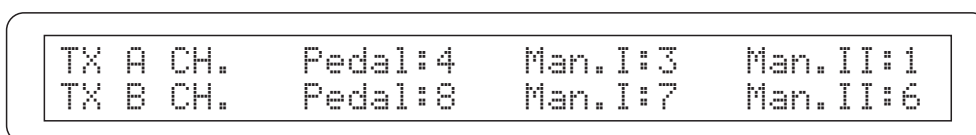

As the video page states, the top line contains the MIDI A channels for each section and the bottom line the MIDI B channels.

Now press CURSOR [▼] to display the video page for setting the reception channels (one for each section):

Prestige 100 - 80:

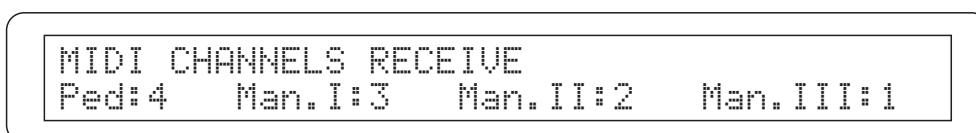

Prestige 70 - 60 - 50 - 40 - 20:

```
MIDI CHANNELS RECEIVE
Pedal:4      Manual I:3      Manual II:2
```

Now press [EXIT] to return to the MIDI menu and save the settings made.

NOTA

MIDI channel n.º 16 is not available because it is a System channel used by internal Viscount MIDI code.

SETTING THE FILTERS

A MIDI filter is a special function which allows a specific message to be cut out **on all the MIDI channels** (if it is a channelled message) in transmission and/or reception.

For example, the note transmission filter allows you not to transmit MIDI notes on the [MIDI OUT] port on all the MIDI channels controlled by the organ.

Similarly, the reception filter cuts out the notes received by the organ by means of the [MIDI IN] port on all the channels (i.e. the notes are not played).

To set up the MIDI filters select the FILTERS field in the MIDI submenu. The following video page appears:

```
FILTER      Note  CC   PG   SysEx  Real
Rx/Tx      N/N  N/N  N/N  N/N    Y/Y
```

The filters for the following messages (shown on the top line of the display) can be switched on and off:

- **Note:** Note On and Note Off (MIDI note messages)
- **CC:** Control Change (control messages)
- **PG:** Program Change (messages for selecting programs/voices)
- **SysEx:** System Exclusive (system exclusive messages)
- **Real:** Real Time messages (Start, Stop, Continue, MIDI Clock and Active Sensing).

The bottom line of the display contains the fields for the setting the filters, for each type of message, identified by two letters. The settings are:

- **N/N:** both filters off.
- **Y/N:** filter only active on messages received

- **N/Y:** filter only active on messages transmitted
- **Y/Y:** filter active on both received and transmitted messages.

When a filter is activated the relative MIDI message is not transmitted / received.

Press [EXIT] to return to the MIDI menu and save the new settings.

N.B.

Transmission MIDI filters are effective on the messages transmitted on both the MIDI A and B channels of each section.

PROGRAM CHANGE MESSAGE TRANSMISSION

A Program Change (PG) message allows a specific sound or program (patch) to be recalled in a connected unit. Therefore, you can use this function to select the voice required from a remote module (such as an expander) connected to the [MIDI OUT] port directly from the organ itself. PG messages can be transmitted on the eight MIDI channels associated to the four sections of the organ (on the MIDI A and MIDI B channels).

To display the relative video page, select the PROGRAM CHANGE field in the MIDI menu and press [ENTER]:

Prestige 100 - 80:

```
MIDI A SEND PROGRAM CHANGE  
Ped:20      M.I:OFF    M.II:44     M.III:OFF
```

Prestige 70 - 60 - 50 - 40 - 20:

```
MIDI A SEND PROGRAM CHANGE  
Pedal:20    Manual I:OFF  Manual II:44
```

This first video page allows PG messages to be transmitted on the organ's MIDI A channels. To transmit a PG message, locate the cursor on the section to which the MIDI channel of choice is associated and turn the encoder. When each value is selected, the relative PG will be transmitted automatically. If, for example, the pedal board MIDI A channel is number 4, when 20 is selected beside the "PED" field, Program Change n. 20 will be transmitted on the MIDI 4 channel.

The next video page, displayed by pressing CURSOR [▼], relates to the transmission of PG messages on the MIDI B channels:

Prestige 100 - 80:

```
MIDI B SEND PROGRAM CHANGE  
Ped:OFF    M.I:OFF    M.II:12     M.III:OFF
```

Prestige 70 - 60 - 50 - 40 - 20:

```
MIDI B SEND PROGRAM CHANGE
Pedal:OFF   Manual I:OFF   Manual II:12
```

It is important to underline that the Program Changes set in these two video pages **are saved in the divisional and general memories**. To do this, simply select the PG messages in the video pages described above and save the memory required.

All this is particularly useful when you are using a remote expander, for example, and wish to obtain a specific voice in combination with the voices switched on using the memory.

If transmission of the PG is not necessary, saving of the PG can be cancelled by selecting the value **OFF** in the video pages shown above.

SETTING THE MIDI VELOCITY

Using the NOTES VELOCITY function, you may set the velocity of the notes transmitted by the [MIDI OUT], and **which are to be used for playing the Orchestra voices**, for each section of the organ.

To recall this function, select the NOTES VELOCITY option from the MIDI submenu; the display will show:

Prestige 100 - 80:

```
MIDI & ORCH. NOTES VELOCITY Ped:127(fix)
M.I:(sense) M.II:(sense) M.III:(sense)
```

Prestige 70 - 60 - 50 - 40 - 20:

```
MIDI & ORCH. NOTES VELOCITY
Ped.: 64(Fix) M.I:(sense) M.II:(sense)
```

For each section, a fixed value (from **1** to **127**) or a velocity which responds to the touch on the keyboard (**sense**) can be set.

N.B.

- *The velocity setting is effective on the notes transmitted on both the MIDI A and B channels of each section.*
- *In view of the characteristics of the pedal board, the “sense” velocity mode cannot be set for this section.*

MIDI NOTE CODE TRANSPOSITION

The last function in the MIDI submenu allows the notes transmitted by the [MIDI OUT] port to be transposed in octaves.

To display the relative video page, select the OCTAVE TRANSPOSER field:

Prestige 100 - 80:

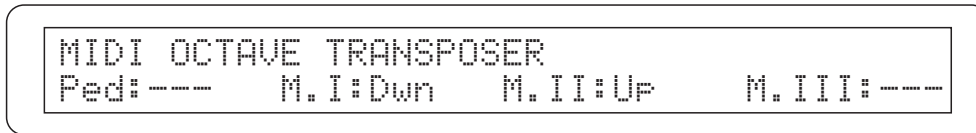

Prestige 70 - 60 - 50 - 40 - 20:

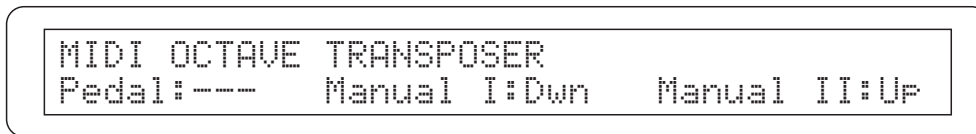

This video page once again consists of the organ section fields, in which you may set **UP** to transpose the notes transmitted up one octave or **DWN** (Down) to transpose them down one octave.

N.B.

- *The transposition governs the MIDI code of the notes transmitted on both the MIDI A and B channels of each section.*
- *This transposition has no effect on the notes played by the internal sound generator.*

6.4 SETTING THE REAR AUDIO OUTPUTS

One of the Prestige series organs' major innovations is the capability for simulating the position of the wind-chests and the arrangement of the pipes inside them, for every voice. All this is achieved by setting the channelling of the audio signals, i.e. the way in which they are distributed, on the rear outputs.

For each voice, the system is able to set an output configuration which reflects the layout of the pipes in real wind-chests, as follows:

- Wedge
- Chromatic
- Left Wing
- Right Wing
- Mono
- Alternate Keys

Moreover, each of these layouts can be further specified with regard to the width of the wind-chest and its central location in relation to the number of outputs connected.

It is important to underline that, in Prestige 100, 80, 70 and 60, the system automatically adapts the channelling to the number of speakers connected. Below is an example with a voice channelled using a “Wedge” wind-chest layout.

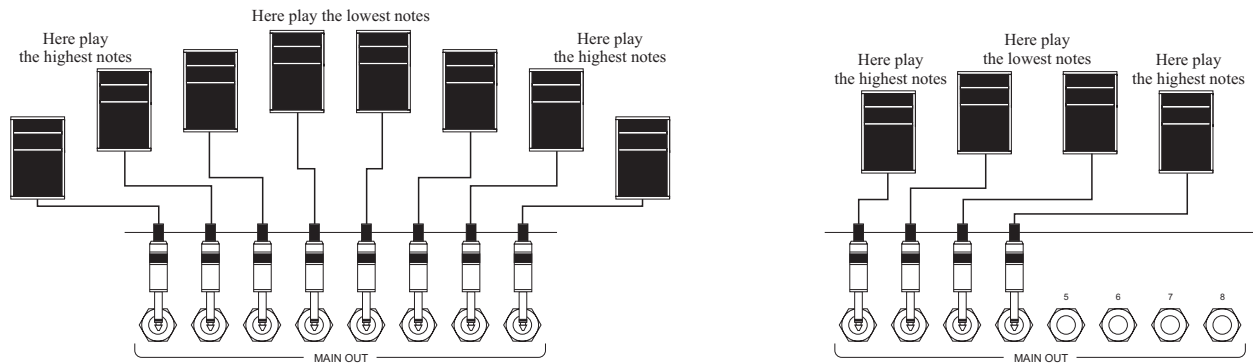

In models Prestige 20, 40 and 50 you have to inform the organ about the number of the used outputs through the item in the display following described in this chapter.

SHORT INTRODUCTION TO THE WIND-CHESTS OF PIPE ORGANS

The wind-chest is a box in which the air from a bellows is distributed. The bellows may be operated by hand or an electric motor, and keeps the air pressurised and ensures it is uniformly distributed through the pipes.

Normally, each manual has its own wind-chest which contains the pipes. However, there are various types of wind-chest, which may contain a single register or have a cascade arrangement with an organ valve (a box full of air filled by the bellows) with the branches leading off to all the registers for each note.

The following is a short description of the wind-chests which the Prestige organ simulates:

- Wedge

In this configuration, the tallest, broadest pipes are located in the centre, so the voice’s lowest notes are played by the most central speakers. As the pitch rises the signal is gradually distributed further and further to the outside, in alternation; in other words, C will sound on the right and C# on the left.

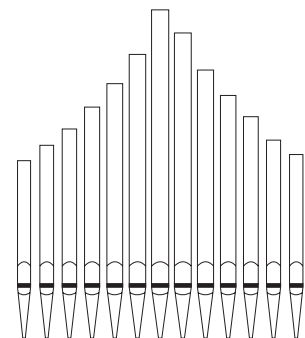

- Chromatic

This configuration is the opposite of the previous one; in this mode, the tallest, broadest pipes are on the outside, so the lowest notes are played on the outermost speakers, again in alternation. As the pitch rises the notes are played closer and closer to the centre.

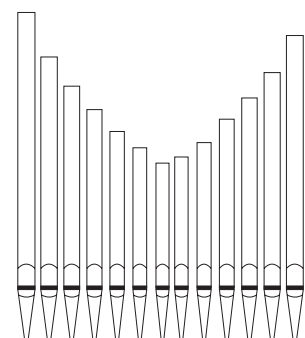

- **Left Wing**

As the video shows, the tallest, broadest pipes are installed on the left, so the lowest notes are played by the speakers furthest to the left. As the pitch rises the notes are played more and more to the right.

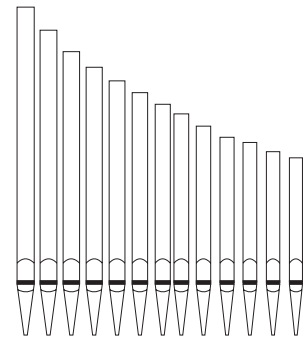

- **Right Wing**

This layout is the reverse of the previous one, so the lowest notes sound on the right and the highest on the left.

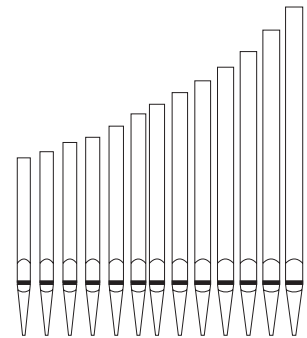

- **Mono**

This setting allows the sound of a voice to be sent to a single output, or a position midway between two outputs. This means that regardless of the point on the keyboard, the voice always sounds from the same position.

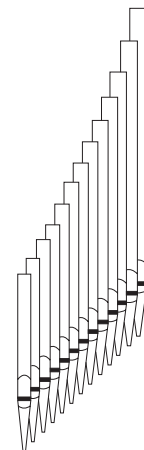

- **Alternate Keys**

In this mode, the notes are sent in alternate semitones to two outputs (or a position midway between two outputs). This means, for example, that C can always be made to sound on output [1] and C# on output [4].

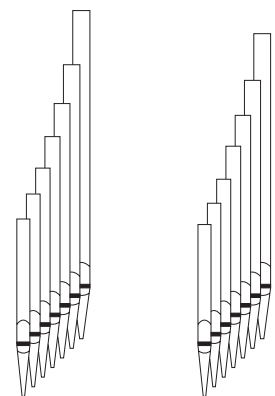

SIMULATING WIND-CHESTS WITH THE PRESTIGE

The output configuration can be set using the EXTERNAL VOICES ROUTER function in the MIDI&UTILITY menu

This display function allows you to select one of the four output Presets developed by our research, which reflect the most classical arrangements of pipes with the wind-chests, and of the wind-chests themselves in large churches and cathedrals.

Two Presets (**Family 1** and **Family 2**) group the outputs together by voice families, while the other two (**Divisional 1** and **Divisional 2**) programme the outputs by divisions (sections) of the organ. This means that all the voices in a given family or on a manual are only found in one group of outputs (in Family 1, for example, all the Principals are only transmitted on outputs [1], [2] and [3]), while another family of voices or another manual will be present on another group of outputs. These groups of outputs are called “**Zones**”.

These divisions of outputs into Zones allow the layout of real wind-chests inside churches to be re-created very easily.

Apart from this, within each Zone the voices are emitted with simulation of the most appropriate type of wind-chest (central peak, two wings, see previous description). A Principal 16' may be distributed to the outputs with simulation of a wind-chest with single wing on the right, while a Principal 8' may be distributed as a single wing on the left, inside the same output zone.

It is as if there were two wind-chests containing different pipe arrangements, but in the same position inside the church. Below you will find a description of the four output Presets available. The output zones and voices they contain are listed underneath the illustration.

PRESTIGE 100 and 80

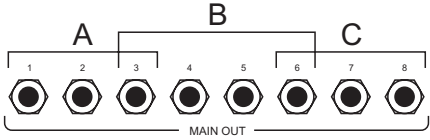
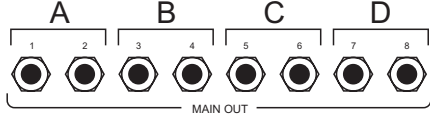
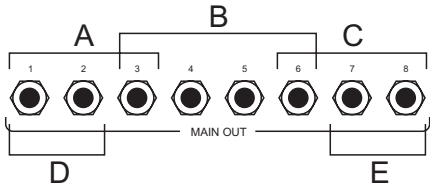
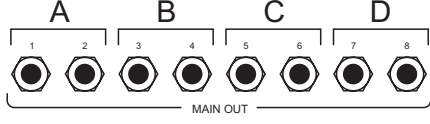
| | |
|---|--|
| <p>FAMILY 1</p>  <p>Zone A: Flutes and Cornets Zone B: Principals, Violas, Mixtures Zone C: Reeds, Chimes</p> | <p>FAMILY 2</p>  <p>Zone A: all 64', 32' and 16' voices Zone B: Flutes, Principals, Violas, Chimes, Cornets and Mixtures (except for those in zone A) Zone C: Reeds Zone D: Tuba Mirabilis (Festival Trumpet)</p> |
| <p>DIVISIONAL 1</p>  <p>Zone A: Man.I voices Zone B: Man.II voices Zone C: Man.III voices Zone D: pedal board voices Zone E: pedal board voices</p> | <p>DIVISIONAL 2</p>  <p>Zone A: Man.I voices Zone B: Man.II voices Zone C: Man.III voices Zone D: pedal board voices</p> |

PRESTIGE 70 and 60

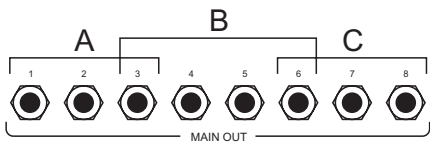
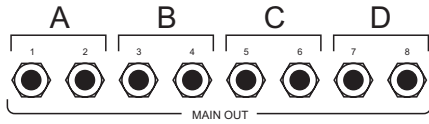
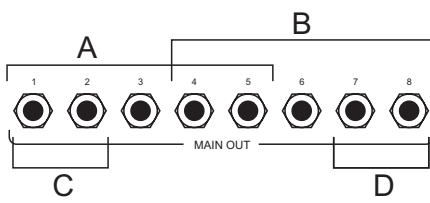
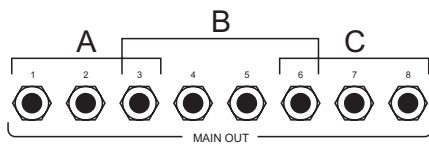
| | |
|---|---|
| <p>FAMILY 1</p>  <p>Zone A: Flutes and Cornets Zone B: Principals, Violas, Mixtures Zone C: Reeds, Chimes</p> | <p>FAMILY 2</p>  <p>Zone A: all 64', 32' and 16' voices Zone B: Flutes, Principals, Violas, Chimes, Cornets and Mixtures (except for those in zone A) Zone C: Reeds Zone D: Tuba Mirabilis (Festival Trumpet)</p> |
| <p>DIVISIONAL 1</p>  <p>Zone A: Man.I voices Zone B: Man.II voices Zone C: pedal board voices Zone D: pedal board voices</p> | <p>DIVISIONAL 2</p>  <p>Zone A: Man.II voices Zone B: Man.I voices Zone C: pedal board voices</p> |

PRESTIGE 50, 40 and 20

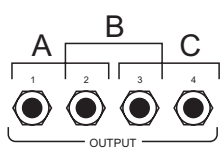
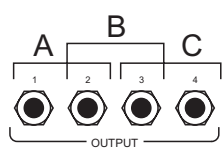
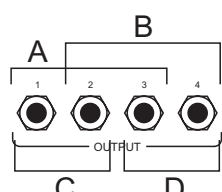
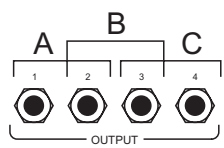
| | |
|---|---|
| <p>FAMILY 1</p>  <p>Zone A: Flutes and Cornets Zone B: Principals, Violas, Mixtures Zone C: Reeds, Chimes</p> | <p>FAMILY 2</p>  <p>Zone A: all 64', 32' and 16' voices Zone B: Flutes, Principals, Violas, Chimes, Cornets, Reeds and Mixtures (except for those in zone A) Zone C: Tuba Mirabilis (Festival Trumpet)</p> |
| <p>DIVISIONAL 1</p>  <p>Zone A: Man.I voices Zone B: Man.II voices Zone C: pedal board voices Zone D: pedal board voices</p> | <p>DIVISIONAL 2</p>  <p>Zone A: Man.II voices Zone B: Man.I voices Zone C: pedal board voices</p> |

To recall the Preset selection function, locate the cursor on the EXT. VOICES ROUTER field in the MIDI&UTILITY menu and press [ENTER]. The video page displayed is as follows:

Prestige 100 - 80 - 70 - 60:

```
EXTERNAL OUTPUTS VOICES ROUTER
Mode:Division1
```

Prestige 50 - 40 - 20:

```
EXTERNAL OUTPUTS VOICES ROUTER
Mode:Division1           Speakers:4
```

The **MODE** parameter allows you to recall the Preset required.

In Prestige models 20, 40 and 50 you have to inform the organ about the number of connected acoustic boxes. Set the outputs number you are using under the item **SPEAKERS**.

Then press [EXIT] to confirm the selection and return to display of the MIDI&UTILITY menu.

WARNING!

- *It is important to remember that if one [MAIN OUT] socket is not connected, the following sockets are also disabled. This means that if socket [2] is disconnected, sockets [3] and [4] and the following sockets will not be enabled.*
- *To prevent wind-chest simulation setup errors, the speakers must be positioned in accordance with the numbering of the outputs. The speaker connected to output [1] must be placed on the far left (looking at the organ from the rear panel). After this, the speakers connected to outputs [2], [3], etc. will be placed further and further to the right, until output [8](in models 100, 80, 70 and 60) or [4] (in models 50, 40 and 20) is positioned on the far right.*

7. FLOPPY DISK AND FILE MANAGEMENT FUNCTIONS

To access the functions for management of floppy disks and the files saved on them, press the [DISK] button **after inserting** a floppy disk in the drive.

The system will first proceed to read the disk and display:

```
*** Reading disk contents ***  
Please wait
```

then:

```
DISK: [LIST] [COPY] [FORMAT] [INFO]  
FILE: [SAVE][LOAD][COPY][REN][DEL][INFO]
```

As the video page shows, the top line contains the functions relating to floppy disks:

- **LIST:** displays the contents of the floppy disk currently inserted in the drive.
- **COPY:** copy of whole floppy disks.
- **FORMAT:** floppy disk formatting.
- **INFO:** general information about the disk inserted in the drive.

The bottom line contains the file management functions:

- **SAVE:** saving on disk of all the memories (general and dedicated, Tutti and Crescendo) and of the instrument's settings (main video page parameters and functions of the VOICES, MIDI&UTILITY and SET-UP menus).
- **LOAD:** loading of the memories and/or organ settings saved using the SAVE function.
- **COPY:** copy of one or more files from one disk to another.
- **REN:** file rename.
- **DEL:** file deletion.
- **INFO:** information about the files saved on the floppy disk inserted in the drive.

To recall a function, simply place the cursor on the field required and press [ENTER]. Otherwise, to exit the menu, press [DISK] or [EXIT].

IMPORTANT NOTES

- *The DISK menu can only be recalled with a floppy disk inserted in the drive.*
- *If the DISK menu is recalled with an unformatted floppy disk inserted, the system will automatically start the formatting function described in point 7.3.*
- *To avoid saving errors and/or damage to floppy disks, never extract the disk when the drive LED is on (reading/writing status).*

7.1 DISPLAYING THE CONTENTS OF FLOPPY DISKS

To check **all** the contents of the floppy disk currently inserted in the drive, simply select the LIST field in the DISK menu and press [ENTER]. The display will show all the files saved on the floppy disk:

```
CUSTOM_.ALL CUSTOM_1.ALL BANK1_.MEM
PRESETS1.MEM DEFAULT_.ALL ERIC_.SET
```

If there are more than 6 files, use the CURSOR [▼] button to display the other video pages and CURSOR [▲] to return to the previous pages.

Finally, press [EXIT] to exit the current function and return to the DISK menu.

7.2 COPYING WHOLE FLOPPY DISKS

To copy the contents of a whole floppy disk onto another one, insert the disk to be copied in the drive and recall the DISK menu. Since the system makes a physical copy (i.e. the whole of the floppy disk is copied, regardless of the amount of data it contains), **the two disks must have the same capacity.**

Now select the COPY option and press [ENTER], the system will proceed to read the data, showing on the display:

```
* * * * * READING * * * * *
█
```

After which you will be prompted to extract the source disk,

```
Extract source disk
█
```

Now extract the floppy disk and **wait** for the prompt for the destination disk (i.e. the disk onto which you wish to copy the data).

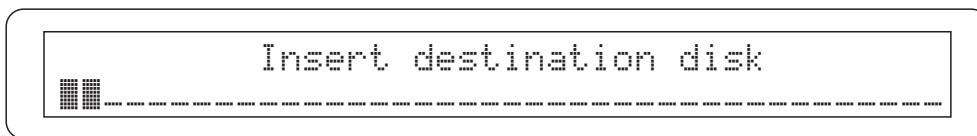

now insert the floppy disk to proceed with writing of the data.

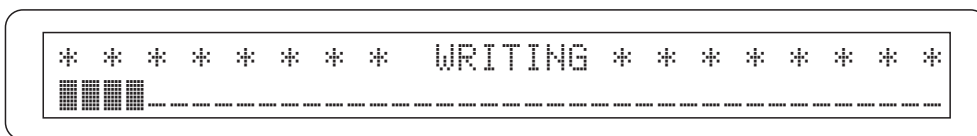

Since a physical copy is made, it will not be possible to copy a whole floppy disk in a single pass, so the system will prompt you to extract the destination disk:

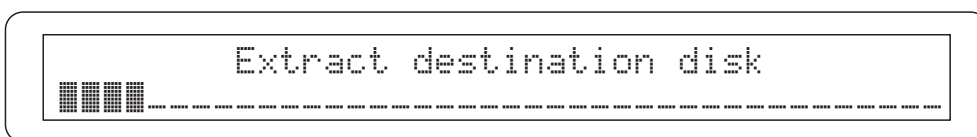

and to re-insert the source disk.

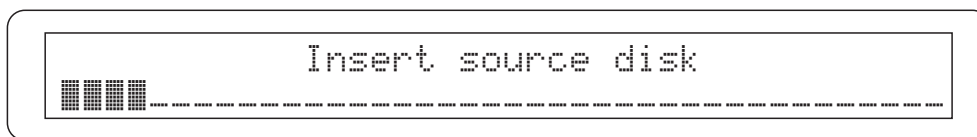

Here again, do not insert the disk until the display shows the relative prompt.

The system will now read the source disk again, and carry out another writing procedure, showing the video pages described above.

To show the percentage of the copy completed, a progress bar appears on the bottom line of the display during the reading and writing operations.

When the copy is complete the display will return to the DISK menu.

During copying, the procedure can be aborted by pressing the [EXIT] button. In this case, wait until the DISK menu is displayed, to allow any open files to be closed.

WARNING!

The Disk Copy function overwrites all the original files present on the destination disk.

7.3 FORMATTING FLOPPY DISKS

If unformatted floppy disks are used, they must be formatted before they can be used with the Prestige. The system formats the disks in MS-DOS® format, so that they can also be used with personal computers and any other system which adopts this standard.

To proceed with formatting, select the FORMAT option in the DISK menu, and press [ENTER]: the display will show the video page for entering the label of the disk:

```
Please enter disk label: DISK____
Press ENTER to format or EXIT to abort
```

To type the Label, use the CURSOR [◀] e [▶] buttons to move the cursor (shown by the flashing letter) and the [VALUE] encoder to enter the characters.

As the video page prompts you, then press [ENTER] to start formatting or [EXIT] to abort the function and return to the DISK menu. During formatting, the display will show:

```
* * * * * * * *   FORMATTING   * * * * * * * *
.....
```

by means of which the system informs you of the percentage of formatting completed.

7.4 DISPLAYING FLOPPY DISK GENERAL PARAMETERS

The DISK INFO function allows you to show the main characteristics of the floppy disk inserted in the drive.

To recall this function, select the INFO option and press the [ENTER] button:

```
DISK LABEL:DISK1____   DISK SIZE:1.44 MB
FREE SPACE: 261 KB     FILES ON DISK: 16
```

The following parameters are displayed:

- **DISK LABEL:** shows the label of the floppy disk.
- **DISK SIZE:** provides information about the disk's capacity.
- **FREE SPACE:** indicates the amount of empty space on the disk.
- **FILE ON DISK:** states the number of files currently stored on the floppy disk.

Press the [EXIT] button to return to display of the DISK menu.

7.5 SAVING THE ORGAN'S MEMORIES AND SETTINGS ON DISK

The FILE SAVE function allows you to save all the organ's general memories and/or settings (including those in the VOICES, MIDI&UTILITY and SET-UP menus) on floppy disks.

To recall this function, place the cursor on the SAVE field in the DISK menu and press [ENTER]:

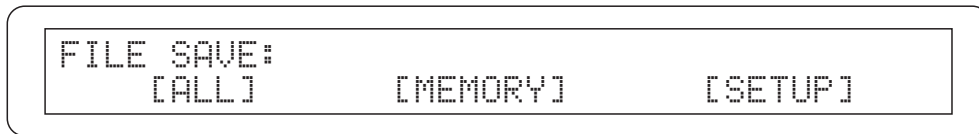

You can use this video page to inform the system about the type of file you wish to save, as follows:

- **ALL:** the following are saved in a file with extension .ALL:
 - General and divisional memories
 - Tutti
 - Crescendo
 - Transposer
 - Ensemble
 - Temperament
 - Tuning
 - Voices Volume function parameters
 - Voices Adjust function parameters
 - Tremulant
 - Reverb
 - Keyboards Setting
 - Internal Equalizer
 - Antiphonal Outputs Settings
 - LCD Contrast
 - External Outputs Control
 - MIDI
 - External Voices Router
 - Orchestra Voices
 - Orchestra Voice Parameters
- **MEMORY:** this function will save a file with extension .MEM containing:
 - General and divisional memories
 - Tutti
 - Crescendo
- **SETUP:** this function will create a file with extension .SET containing:
 - Transposer
 - Ensemble
 - Temperament
 - Tuning
 - Voices Volume function parameters
 - Voices Adjust function parameters
 - Tremulant
 - Reverb
 - Keyboards Setting

- Internal Equalizer
- Antiphonal Outputs Settings
- LCD Contrast
- External Outputs Control
- MIDI
- Orchestra Voices
- Orchestra Voice Parameters

Now use the cursor keys and the [ENTER] button to select the type of saving operation you require. The display will show the video page for composition of the name of the file to be saved:

```
FILE SAVE:
FILE:DEFAULT_.ALL - Press ENTER to start
```

With the usual procedure, use the [CURSOR] keys to move the cursor and the encoder to select the letter you require. After the saving procedure has been confirmed using the [ENTER] button, the following video page will appear for a few moments:

```
* * * * * SAVING * * * * *
FILE: DEFAULT_.ALL
```

informing you that the system is proceeding to write the file, after which the display will return to the DISK menu.

If the following message should appear before the video page shown above:

```
File already exists, overwrite?
Press ENTER to confirm or EXIT to abort
```

the floppy disk already contains a file with the name (and, of course, the extension) of the one you are saving. Press [ENTER] to overwrite the original file or [EXIT] to abort the saving operation.

7.6 LOADING THE ORGAN'S MEMORIES AND SETTINGS SAVED ON DISK

To load the memories and/or settings saved on a disk with the FILE SAVE function into the organ's internal memory, the FILE LOAD function has to be recalled. To do this, locate the cursor on the LOAD field and press [ENTER]: the display will show the first 6 organ memory and setting files on the floppy disk.

```
CUSTOM_.ALL CUSTOM_1.ALL BANK1_.MEM  
PRESETS1.MEM DEFAULT_.ALL ERIC_.SET
```

Use the CURSOR [▼] button to display the other files. Now locate the cursor on the file you wish to load and press [ENTER]; the display will show a confirmation prompt to avoid loading the wrong file:

```
FILE LOAD:  
FILE:PRESETS1.MEM - Press ENTER to start
```

As the video page requests, press [ENTER] again to load the data in the memory, or press [EXIT] to abort the operation.

If you confirm, the system will proceed to load the selected file in the internal memory, displaying the following video page for all the time needed to complete the operation:

```
* * * * * LOADING * * * * *  
FILE: PRESETS1.MEM
```

IMPORTANT NOTE

Bear in mind that when a file is loaded the settings and memories currently present in the organ will be lost. To avoid this, it is best first to carry out a File Save of the current memories and settings, and then to load the file required.

7.7 COPYING INDIVIDUAL FILES

If you wish to copy one or more files from one floppy disk to another, recall the FILE COPY function. This is done by selecting the COPY field on the bottom line of the DISK menu and pressing [ENTER].

```
[DIRECTORY]      [* .ALL]      [* .MEM]
[* .SET]        [* .MID]      [* .*]
```

Use this video page to inform the system about the file(s) you wish to copy. The fields refer to the procedures for copying:

- **DIRECTORY:** one of the files on the disk.
- ***.ALL:** all the files with extension .ALL (i.e. the files in which the organ's general settings and memories are saved).
- ***.MEM:** all the files with extension .MEM (the general and divisional memories, Tutti and Crescendo).
- ***.SET:** all the files with extension .SET (the organ's general settings).
- ***.MID:** all the files with extension .MID (the MIDI sequences recorded with the sequencer).
- ***.*:** all the files on the floppy disk.

After selecting the copy option press [ENTER]. The system will proceed to read the first file with the selected extension on the source disk:

```
FILE COPY:
PRESETS1.MEM
```

If you have recalled the DIRECTORY copy function, after [ENTER] is pressed the display will show all the files on the disk:

```
CUSTOM_ .ALL  CUSTOM_1.ALL  BANK1_ .MEM
PRESETS1.MEM  DEFAULT_ .ALL  ERIC_ .SET
```

Use the [CURSOR] keys to select the file you wish to copy and press [ENTER]. If there are more than 6 files, use the CURSOR [▼] button to show the other files:

After the copying procedure is started, the display will show:

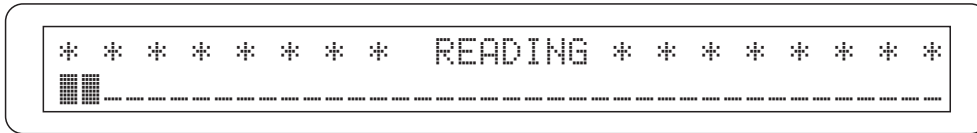

When reading of the first file is complete, you will be prompted to extract the source disk:

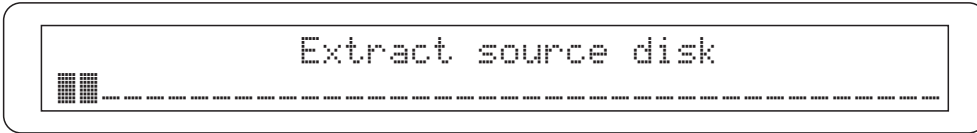

and insert the destination disk (i.e. the disk onto which you wish to copy the files).

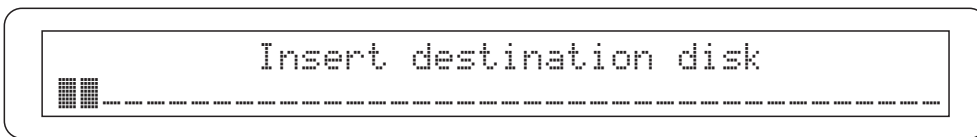

The system will then proceed to write the file:

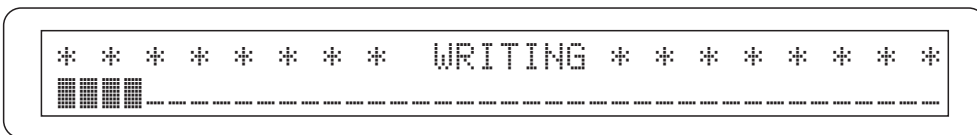

In case of a multiple copying operation (*.ALL, *.MEM, *.SET, *.MID and *.*), if there are more files to be copied, you will have to extract the destination disk:

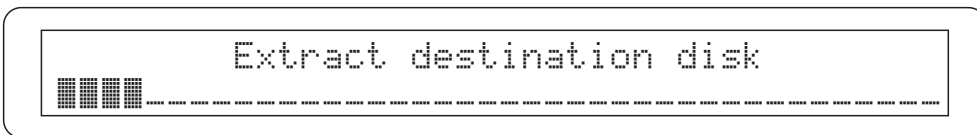

and re-insert the source disk:

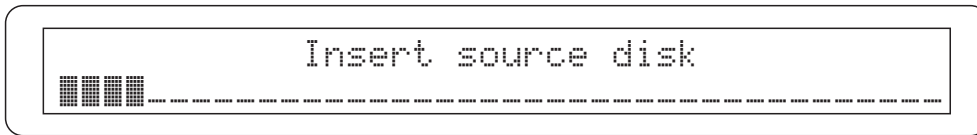

and carry out another reading and writing session, following the video pages shown above. When all the files have been copied, the system will prompt you to reinsert the source disk, and then return to display of the DISK menu.

N.B.
Bear in mind that any files on the destination disk with the same names as those being copied will automatically be overwritten.

7.8 RENAMING FILES

The FILE RENAME function allows you to rename the files saved on floppy disks. To recall this function, select the REN field and press the [ENTER] button; the display will show the contents of the floppy disk:

```
CUSTOM___.ALL CUSTOM_1.ALL BANK1____.MEM
PRESETS1.MEM DEFAULT___.ALL ERIC_____.SET
```

now use the [CURSOR] buttons to select the file you wish to rename and press [ENTER].

```
RENAME FILE      ACTUAL NAME:PRESETS1.MEM
                  NEW NAME:PRESETS1.MEM
```

The display now shows a video page consisting of two fields: **ACTUAL NAME** contains the current name of the selected file. **NEW NAME** allows you to type the new name.

As usual, use the [CURSOR] buttons to move the cursor and the [VALUE] encoder to enter the letter you require.

Once you have created the new name, press [ENTER] to complete the operation.

Press [EXIT] to abort the function and leave the name of the file unchanged.

If you confirm the rename, the following video page will appear for a few moments:

```
* * * * * RENAMING * * * * *
FILE: PRESETS1.MEM
```

which also informs you about the file you have just renamed.

If you rename a file with a name already present on the floppy disk, the display will show the message:

```
Error:
File already exists
```

indicating that the operation cannot be completed. Rename the file with a different name.

7.9 DELETING FILES

To delete any files saved on floppy disks, recall the FILE DELETE function in the DISK menu: to do this, select the DEL option and press [ENTER].

```
[DIRECTORY]      [* .ALL]      [* .MEM]
[* .SET]        [* .MID]      [* .*]
```

These display options allow you to delete:

- **DIRECTORY:** one of the files on the disk.
- ***.ALL:** all the files with extension .ALL (i.e. the files in which the organ's general settings and memories are saved).
- ***.MEM:** all the files with extension .MEM (the general and dedicated memories, Tutti and Crescendo).
- ***.SET:** all the files with extension .SET (the organ's general settings).
- ***.MID:** all the files with extension .MID (the MIDI sequences recorded with the sequencer).
- ***.*:** all the files on the floppy disk.

If you select a multiple deletion procedure (*.ALL, *.MEM, *.SET, *.MID e *.*) the system will warn you of the chosen procedure and wait for you to confirm with [ENTER] or abort the operation by pressing [EXIT]:

```
Multiple file delete requested
Press ENTER to delete or EXIT to abort
```

If the DIRECTORY option has been selected, the display will show the entire contents of the disk, to allow you to select the file you wish to delete:

```
CUSTOM_...ALL CUSTOM_1.ALL BANK1_...MEM
PRESETS1.MEM DEFAULT_...ALL ERIC_...SET
```

Here again, to avoid accidental deletions the display will show a confirmation prompt indicating the name of the file about to be deleted:

```
FILE DELETE:PRESETS_...SET Are you sure?
Press ENTER to delete or EXIT to abort
```

Now press [ENTER] to complete the operation or [EXIT] to abort the entire function.

During deletion, the following video page will be displayed:

```
* * * * * * * * * DELETING * * * * * * * * *
      FILE: PRESETS_.MID
```

which informs you about the file being deleted.

7.10 FILE INFORMATION

If you require information, such as size and type, about the files on the floppy disks, recall the FILE INFO function in the DISK menu. To do this, select the INFO option and press [ENTER].

All the files on the disk are displayed:

```
CUSTOM_..ALL CUSTOM_1.ALL BANK1_...MEM
PRESETS1.MEM DEFAULT_..ALL ERIC_...SET
```

Now select the file you require by the usual procedures and press [ENTER]:

```
FILE INFO: BANK3_...MEM
Size:      15 Kbyte      Type: MEMORY
```

The following parameters are displayed:

- **FILE INFO:** indicates the file to which the information displayed relates:
- **SIZE:** states the size of the file.
- **TYPE:** displays the type of file selected, as follows:
 - ALL: file in which the organ's general settings and memories are saved.
 - MEMORY: file in which all the memories are saved.
 - SETUP: organ general settings.
 - MIDI FILE: MIDI Standard Files (including those not recorded with the organ's sequencer)
 - MANUAL VOICE: files of one manual voice.
 - PEDAL VOICE: files of one pedal board voice.
 - VOICES GROUP: group of voices.

Press [EXIT] to return to display of the DISK menu.

7.11 ERROR MESSAGES - DISK MENU

- DISK NOT IN DRIVE

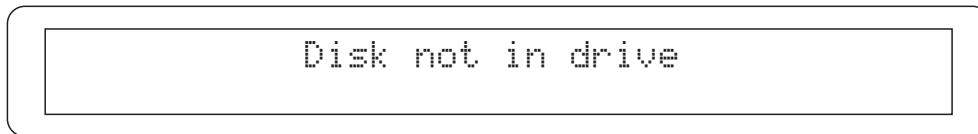

The DISK menu has been recalled with no floppy disk inserted in the drive.

- NO FILES

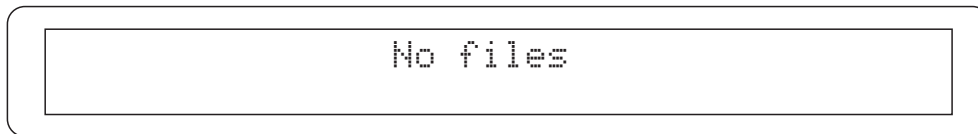

There is no file on the floppy disk for completion of the current operation.

- DISK NOT FORMATTED

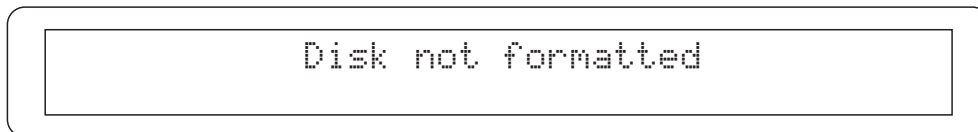

An unformatted disk has been inserted. After this error message is displayed the system starts the formatting procedure automatically.

- DISK IS WRITE PROTECTED

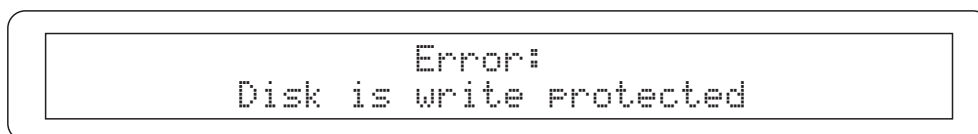

The disk has write-protection so it is not possible to complete the current operation. Remove the protection (the window in the top right-hand corner of the floppy disk must be open) and repeat the operation.

- WRONG TARGET SIZE

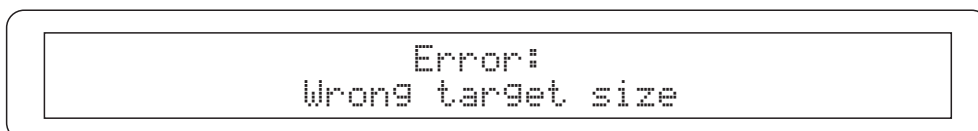

During a floppy disk copy operation, a destination disk with capacity different from the source disk has been inserted. Remove the floppy disk and repeat the operation with the right disk.

- **DISK IS FULL**

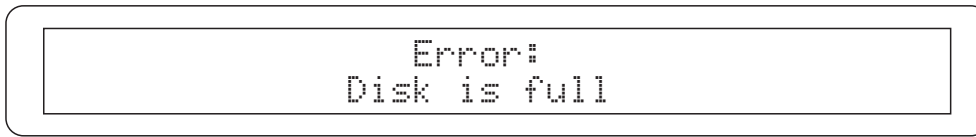

There is not enough empty space on the floppy disk inserted for completion of the file copying or saving operation. Replace the disk or free some space.

- **SAVE ERROR**

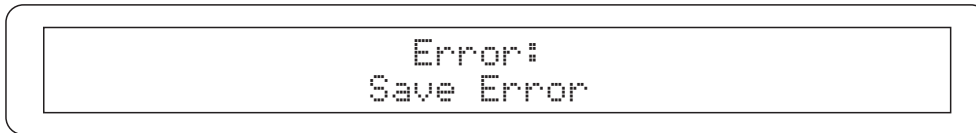

A serious error has occurred during writing on the floppy disk. The disk might be damaged. Try formatting the disk to correct the errors.

- **LOAD ERROR**

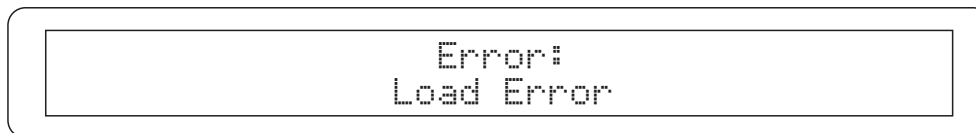

A serious error has occurred during reading on the floppy disk. The disk might be damaged. Try formatting the disk to correct the errors.

8. SEQUENCER

Prestige organs are equipped with a multitrack sequencer allowing the user to record, save on floppy disk and play back musical performances. The system also allows MIDI sequences to be recorded in multidubbing mode (i.e. in a number of stages).

Each of the organ's sections (Man.I, Man.II, Man.III and pedal board) is recorded on a different track, while a fifth track records the states of the registers, Tutti, Crescendo, Couplings and the manual settings. The names of these tracks are as follows:

- **PD** (Pedal): the track used to record the note and volume events performed on the pedal board.
- **M.I** (Man.I): the track used to record the first manual events.
- **M.II** (Man.II): the track used to record the second manual events.
- **M.III.** (Man.III, only in Prestige 100 and 80): track for the third manual events.
- **CM** (Common): "common" track which can be used to record:
 - Voices (pipe organ and Orchestra)
 - Couplings
 - Reed and Mixture Cancel
 - Enclosed
 - Automatic Pedal
 - Midi To A / B
 - Organ Solo

The sequence is able to record musical sequences up to a maximum of 60,000 MIDI events with a resolution of 192 tpqn (ticks per quarter note, or crotchet).

The recordings are saved on floppy disks as MIDI (.mid) files in format 1. In this format, the channels used to record the accompaniments are subdivided by tracks (unlike format 0, which combines all the channels on a single track), keeping the organ's sections subdivided for quicker, easier interpretation.

This means that the songs recorded are compatible with even the most run-of-the-mill computer MIDI software packages (for creating and printing out scores, modifying the song's advanced parameters, and so on).

8.1 RECORDING A PERFORMANCE

FIRST RECORDING

To start a recording session, simply press the [RECORD] button after inserting a floppy disk in the drive.

The system will proceed to read the disk and display:

```
*** Reading disk contents ***  
Please wait
```

after which it will show the video page used to set up the recording:

Prestige 100 - 80:

```
RECORD:NEWSONG      Tempo:120      Meas: 1
PD:REC M.I:REC M.II:REC M.III:REC CM:REC
```

Prestige 70 - 60 - 50 - 40 - 20:

```
RECORD:NEWSONG      Tempo:120      Meas:1
Ped:REC ManI:REC ManII:REC Common:REC
```

consisting of the following fields:

- **RECORD:** this displays the name of the MIDI sequence being recorded. For each new recording, the name “NEWSONG” will always appear, while during a multidubbing recording, the song’s current name will be displayed.
- **TEMPO:** indicates the current metronome tempo. Locate the cursor on this parameter and use the encoder if you wish to modify its value.
- **MEAS:** displays the bar (measure) reached in the recording.
- **PD – M.I – M.II – M.III (only in models 100 and 80) – CM:** these parameters set the status of the Pedal, Man.I, Man.II, Man.III and Common tracks, as follows:
 - **REC:** track being used to record the events performed on the organ.
 - **- - -:** the selected track is not included in the recording. The events performed on the relative section are not recorded.

Then press [START-STOP] to start the recording. The sequencer will start with the number of precount bars set earlier (-1 in default condition) and the Led of the [START-STOP] button will flash in time with the current tempo set.

To modify the number of precount bars and the time signature, keep the [METRONOME] button pressed for a few moments before starting to record, and follow the instructions provided in point 8.3.

Otherwise, use [RECORD] or [EXIT] before starting to record to exit the sequencer function and return to display of the main video page.

MULTIDUBBING RECORDING

Multidubbing recording means that the sequencer is able to record the tracks of a given MIDI sequence over a number of sessions.

If you wish to re-record one or more tracks of a sequence just recorded (and comprising the tracks marked with the PLY code on the display),

Prestige 100 - 80:

```
RECORD:SESSION1  Tempo:120  Meas: 1  
PD:--- M.I:PLY M.II:PLY M.III:PLY CM:PLY
```

Prestige 70 - 60 - 50 - 40 - 20:

```
RECORD:SESSION1  Tempo:120  Meas:1  
PD:--- ManI:PLY ManII:PLY Common:PLY
```

set the track required on REC. To do this, simply locate the cursor on the track concerned using the [CURSOR] keys and select REC with the [VALUE] encoder.

Prestige 100 - 80:

```
RECORD:SESSION1  Tempo:120  Meas: 1  
PD:--- M.I:REC M.II:PLY M.III:PLY CM:PLY
```

Prestige 70 - 60 - 50 - 40 - 20:

```
RECORD:SESSION1  Tempo:120  Meas: 1  
PD:--- ManI:REC ManII:PLY Common:PLY
```

Now, when a new recording session is started using the [START-STOP] button, the tracks in Play status (PLY on the display) are played normally, while those set in Record status (REC on the display) will be re-recorded, overwriting the original data.

If you wish to modify a song recorded earlier and saved on the floppy disk, display the recording video page then locate the cursor on the RECORD field and press the [ENTER] button.

All the .MID files present on the floppy disk will be displayed:

```
ERICSONG.MID SESSION1.MID RECORD_1.MID  
RECORD_2.MID RECORD_3.MID
```

Use the cursor keys and [ENTER] to select the song of your choice; the display will show:

```
* * * * * LOADING SONG * * * * *
```

for the time it takes to load the song, and then:

Prestige 100 - 80:

```
RECORD:RECORD_1   Tempo:103   Meas: 1
PD:FLY M.I:FLY M.II:FLY M.III:FLY CM:FLY
```

Prestige 70 - 60 - 50 - 40 - 20:

```
RECORD:RECORD_1   Tempo:103   Meas: 1
PD:FLY ManI:FLY ManII:FLY Common:FLY
```

Here again, the tracks that make up the MIDI sequence are identified by the PLY code. Set REC for the tracks you wish to record.

The [CURSOR] keys can also be used to locate the cursor on the TEMPO field, to modify the metronome tempo.

After setting all the parameters, press [START-STOP] to start the recording / playback. The sequencer will start with the number of precount bars set earlier and the Led of the [START-STOP] button will flash in time with the current tempo and the Time Signature set.

To stop the recording, press [START / STOP] again. The display shows the video page for saving the sequence just recorded, in which the name of the song can be entered:

```
SEQUENCER SAVE:
SONG:SESSION1.MID - Press ENTER to start
```

With the usual procedure, use the [CURSOR] buttons to move the cursor and the encoder to select the characters. Then press [ENTER] to save the recording on the floppy disk [EXIT] to abort the saving operation.

WARNING!

To make sure that existing recordings are not lost, when entering the name of the song take care not to enter a name already on the disk. Otherwise, the original file will automatically be overwritten.

8.2 PLAYING BACK A PERFORMANCE

To play back a song recorded using the sequencer, insert the floppy disk in the drive and press [PLAY]. The system will proceed to read the floppy disk:

```
*** Reading disk contents ***  
Please wait
```

after which all the songs (.MID files) saved on the disk will be displayed:

```
ERICSONG.MID SESSION1.MID RECORD_1.MID  
RECORD_2.MID RECORD_3.MID
```

Use the [CURSOR] keys to select the song you wish to play and press [ENTER]. The display will show the page:

Prestige 100 - 80:

```
PLAY:SESSION1 Tempo:120 Meas: 1  
FD:--- M.I:PLY M.II:PLY M.III:PLY CM:PLY
```

Prestige 70 - 60 - 50 - 40 - 20:

```
PLAY:SESSION1 Tempo:120 Meas:1  
Fed:--- ManI:PLY ManII:PLY Common:PLY
```

As described in the previous point, the tracks which make up the song are identified by the PLY code.

You may locate the cursor on the TEMPO parameter and then use the [VALUE] encoder to change the tempo at which the MIDI sequence will be played.

Now press [START-STOP] to start playback of the performance recorded earlier. The LED of the key starts to flash in time with the current tempo and Time Signature.

If you wish to stop playback temporarily (pause), press the [PLAY] button; press the same button again to restart the song from the point where it was interrupted.

To stop the playback, press [START- STOP] again.

To exit the sequencer Play mode, press [EXIT] or [PLAY].

8.3 SWITCHING ON AND SETTING THE METRONOME

The Prestige sequencer features its own metronome, activated by pressing the [METRONOME] button in the group of sequencer buttons. The LED of the key displays the function's status: when the LED is lit, the metronome is on. The metronome speed can be set by means of the TEMPO parameter in the sequencer video pages (both Record and Play), while the downbeat will depend on the Time Signature setting. To set up the metronome's internal parameters, keep the [METRONOME] button pressed for a few moments. The following video page will be displayed:

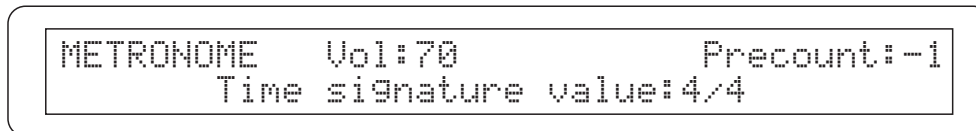

```

METRONOME   Vol:70           Precount:-1
            Time signature value:4/4
  
```

containing the following parameters:

- **VOL:** regulates the metronome's volume.
- **PRECOUNT:** sets the number of Precount bars, meaning the number of bars after which the sequencer will start to record.
- **TIME SIGNATURE VALUE:** sets the time signature to be used for making a recording, or for playing back a sequence recorded earlier. The possible values are: 1/4, 2/4, 3/4, 4/4, 5/4, 7/4, 3/8, 6/8, 9/8 and 12/8.

Then press [EXIT] to save the new settings and return to display of the sequencer video page.

8.4 ERROR MESSAGES - SEQUENCER SECTION

- DISK NOT IN DRIVE

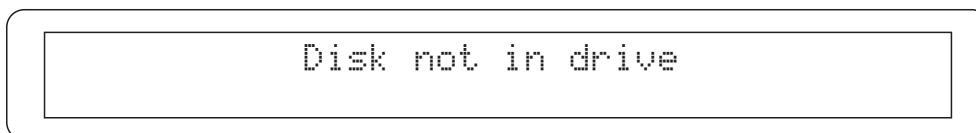

```

Disk not in drive
  
```

The sequencer (Play or Record) has been recalled with no floppy disk inserted in the drive. Insert the disk and repeat the operation.

- DISK NOT FORMATTED

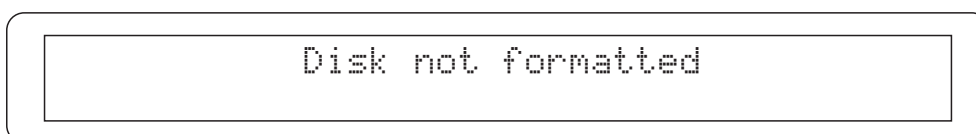

```

Disk not formatted
  
```

The sequencer (Play or Record) has been recalled with an unformatted floppy disk. Format the disk and repeat the procedure.

- **NO FILES**

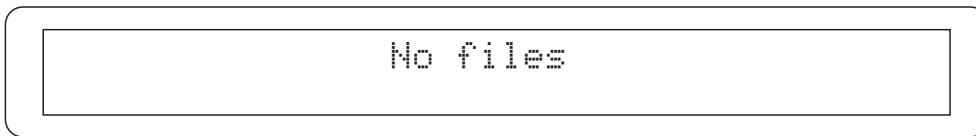

The Sequencer has been recalled in Play mode with no .MID files on the floppy disk.

- **DISK IS WRITE PROTECTED**

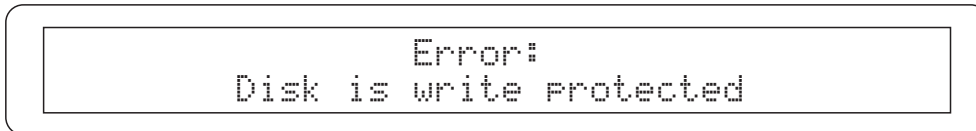

You have attempted to save a song on a write-protected floppy disk. Remove the protection and repeat the procedure.

- **DISK FULL**

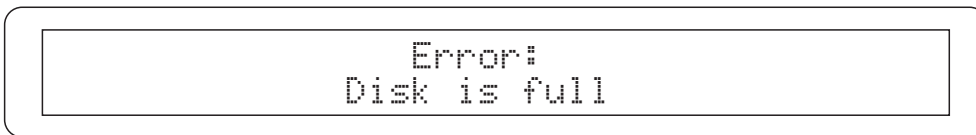

There is not enough room on the disk where you have attempted to save a song to complete the operation. Free space on the disk or use another one.

- **SAVE ERROR**

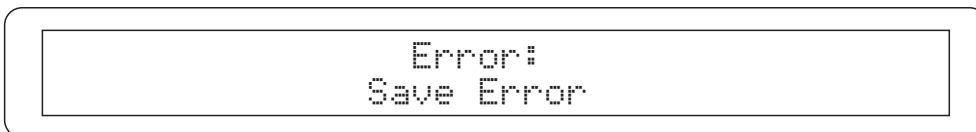

A serious error has occurred during writing on the floppy disk. The disk might be damaged. Try formatting the disk to correct the errors.

- **LOAD ERROR**

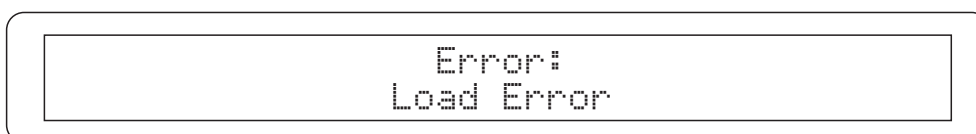

A serious error has occurred during reading on the floppy disk. The disk might be damaged. Try formatting the disk to correct the errors.

9. APPENDIX

9.1 VOICE LOCAL OFF

Setting a voice in Local Off mode means that it will not be played by the organ's internal sound generation system, but the relative MIDI (System Exclusive) message will be transmitted, so that it can be turned on and played on a connected instrument.

To set a voice Local Off press the [S] (Set) button, keep it pressed and also press the [C] (Cancel) button. All the draw-stops will come on and the display will show the video page:

```

LOCAL ON/OFF STOPS SETTINGS
*****

```

To set a voice in Local Off mode, press its draw-stop or stop or tab so that its light goes out. After setting the setup required, press [S] and [C] together to save it.

Accessing the Local Off setting function after this will trigger display of the status of the voices as follows:

- Light on: voice in Local On mode (plays with internal generation)
- Light off: voice in Local Off status

During normal operation, when a voice in Local off mode is switched on, the draw-stop or stop flashes twice then remains constantly lit.

9.2 FACTORY SETTING

With the operation of the Factory Setting, all functions will return to factory setting, cancelling the changes made by the user.

To recall this procedure, press switches, CURSOR [▲] and [▼] together, and keep them pressed down whilst switching the organ on. The following video page will appear:

```

Factory Setting in progress

```

9.3 UPDATING THE FIRMWARES

Prestige organs use two firmware packages:

- **OPERATING SYSTEM:** operating system controlling all the organ's sections, the user interface, the sequencer and the MIDI functions.

The update files for this section are called:

Prestige 100 and 80: **PE3Nxxxx.SYS**

Prestige 70 and 60: **PE2Nxxxx.SYS**

Prestige 50 and 40: **PE22xxxx.SYS**

Prestige 20: **PE23xxxx.SYS**

- **SOUND DRIVER:** sound generation firmware.

The update file for this section is called:

PRESCxxx.DRV

The "xxx" letters stand for the firmware release.

UPDATING THE OPERATING SYSTEM FIRMWARE

Switch on the organ keeping the CURSOR [◀] and [▶] buttons depressed, with the floppy disk containing the update file inserted in the drive. The system will proceed to check the file on the floppy disk:

```
SYSTEM FILE DETECTED    PE3N2200.SYS
  Integrity and version checking
```

indicating the release of the firmware being installed:

```
Updating to
Operating Sys. Version 2.200
```

The file will then be read and loaded into the memory:

```
Loading System...
```

after which the relative check will be made.



When the procedure is complete, the following video page will be displayed:

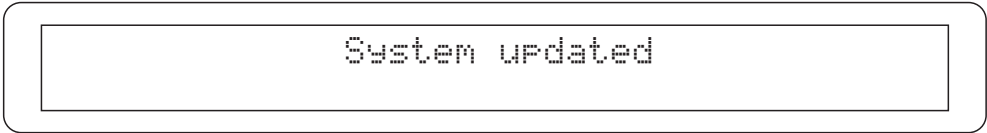

WARNING!
It is particularly important to ensure that the floppy disk used to update the Master firmware only contains one .SYS file.

UPDATING THE SOUND DRIVER FIRMWARE

Recall the FILE LOAD function in the DISK menu (see point 7.6) and select the .DRV file with the Sound Driver firmware update.

During loading, the following video page is displayed:

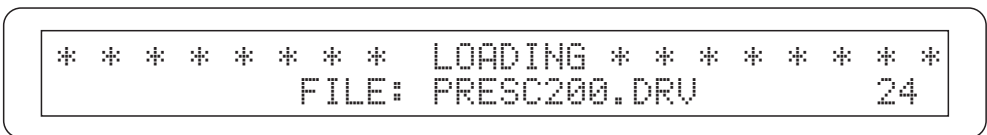

indicating the percentage of the data loaded in the memory. When the procedure is complete, the following video page is displayed:

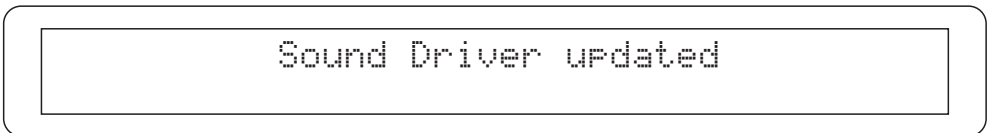

After which the organ will perform an automatic reboot to reconfigure all the systems.

ERROR MESSAGES - FIRMWARE UPGRADE

- SYSTEM FILE ERROR

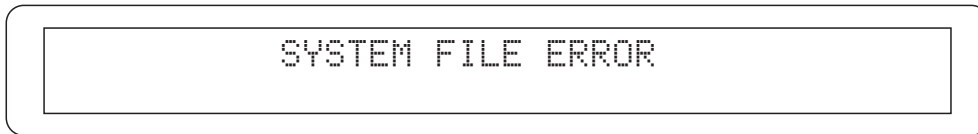

The Operating System software update file is damaged. Repeat the procedure using an error-free file and disk.

- UNABLE TO UPDATE SOUND DRIVER

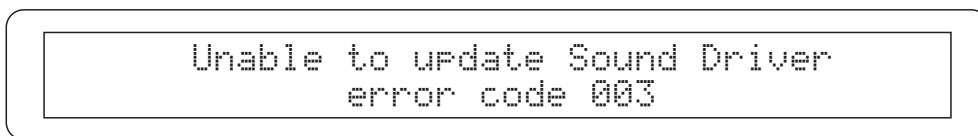

The system is not able to install the Sound Driver section update. Repeat the update procedure using another floppy disk.

If the problem persists, contact your nearest service centre, quoting the Error Code shown on the display.

- PROGRAM FLASH ERROR / VERIFY ERROR / CHECKING ERROR

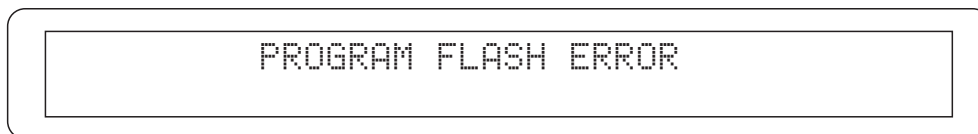
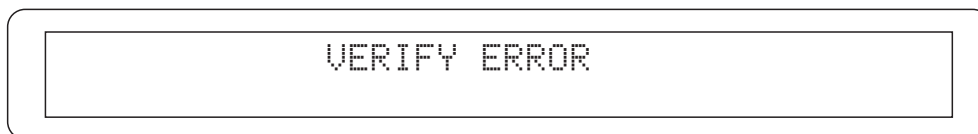
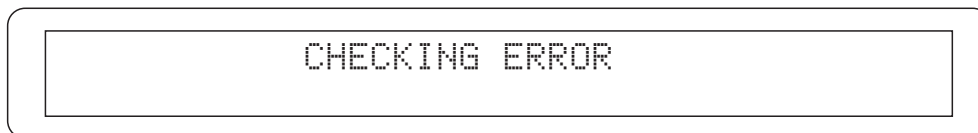

A serious error has occurred during loading of the firmware into the memory. Contact your nearest service centre, stating the type of error shown on the display.

- SLAVE CPU WRONG START

```
ERROR!!!  
Slave CPU wrong start (TIMEOUT)
```

This error is displayed when, switching the organ, the Slave CPU is not functioning. Try to install the latest version of the firmware Sound Driver. If it continues displaying the error, please contact your nearest assistance point.

9.4 CHECKING THE RELEASES OF THE FIRMWARE PACKAGES INSTALLED IN THE ORGAN

Switch on the organ with the [ENTER] and [START-STOP] buttons pressed; the display shows the video page containing the releases of the firmware packages currently installed in the organ:

```
OperatingSystem:1.0   SoundDriver:1.0  
HIF(Pan-Kbd):1.0-1.0 Loader:1.0
```

- **OPERATING SYSTEM:** Operating System firmware release
- **SOUND DRIVER:** Sound Driver firmware release
- **HIF:** releases of the firmware packages which control the panels (PAN) and the manuals (KBD)
- **LOADER:** Loader firmware release

Press [EXIT] to continue with the organ switch-on.

FCC RULES

NOTE: This equipment has been tested and found to comply with the limits for a **Class B** digital Device, pursuant to Part 15 of the FCC Rules. These limits are designed to provide reasonable protection against harmful interference in a residential installation. This equipment generates, uses and can radiate radio frequency energy and, if not installed and used in accordance with the instruction, may cause harmful interference to radio communications. However, there is no guarantee that the interference will not occur in a particular installation. If this equipment does cause harmful interference to radio or television reception, which can be determined by turning the equipment off and on, the user is encouraged to try to correct the interference by one or more of the following measures:

- Reorient or relocate the receiving antenna.
- Increase the separation between the equipment and receiver.
- Connect the equipment into an outlet on a circuit different from that to which the receiver is connected.
- Consult the dealer or an experienced Radio/TV technician for help.

The user is cautioned that any changes or modification not expressly approved by the party responsible for compliance could void the user's authority to operate the equipment.

MIDI IMPLEMENTATION CHART

Viscount Prestige
Classic Organ

Version: 1.0
Date: 19/07/05

| FUNCTION... | TRANSMITTED | RECEIVED | REMARKS |
|------------------------------|---|----------|-----------------------|
| BASIC Default | 1÷15 | 1÷15 | *1 |
| CHANNEL Changed | 1÷15 | 1÷15 | |
| MODE Default | Mode 3 | Mode 3 | |
| Messages | ***** | ***** | |
| Altered | ***** | ***** | |
| NOTE | 30÷101 | 30÷101 | |
| NUMBER True Voice | 36÷96 | 30÷101 | |
| VELOCITY Note ON | O | O | |
| Note OFF | X | X | |
| AFTER Key's | X | X | |
| TOUCH Ch's | X | X | |
| PITCH BENDER | O | O | *2 |
| CONTROL 7 | O | O | Volume |
| CHANGE 11 | O | O | Expression |
| 64 | O | O | Sustain |
| 120 | O | O | All sound off |
| 121 | O | O | Reset All Controllers |
| 123 | O | O | All Notes Off |
| PROGRAM | O | X | |
| CHANGE True# | | | |
| SYSTEM EXCLUSIVE | O | O | |
| SYSTEM Song Pos | X | X | |
| COMMON Song Sel | X | X | |
| Tune | X | X | |
| SYSTEM Clock | O | O | *3 |
| REAL TIME Commands | O | O | |
| AUX Local On-Off | X | X | |
| MESSAGES All note off | O | O | |
| Active Sense | O | X | |
| Reset | X | X | |
| NOTES: | *1: see par. 6.3 for further informations *2: received Pitch Bend code is applied to the Orchestra voices only *3: these messages are used to control the sequencer | | |

Mode 1: Omni On, Poly
Mode 3: Omni Off, Poly

Mode 2: Omni On, Mono
Mode 4: Omni Off, Mono

viscount

Viscount International S.p.A.

Via Borgo n.° 68/70 – 47836 Mondaino (RN), ITALY

From Italy: TEL: 0541-981700 FAX: 0541-981052

From all other countries: TEL: +39-0541-981700 FAX: +39-0541-981052

E-MAIL: organs@viscount.it

WEB: <http://www.viscount-organs.com>

<http://www.viscount.it>